

# D

**Z5601.002**  
**Manual 1.2 en**

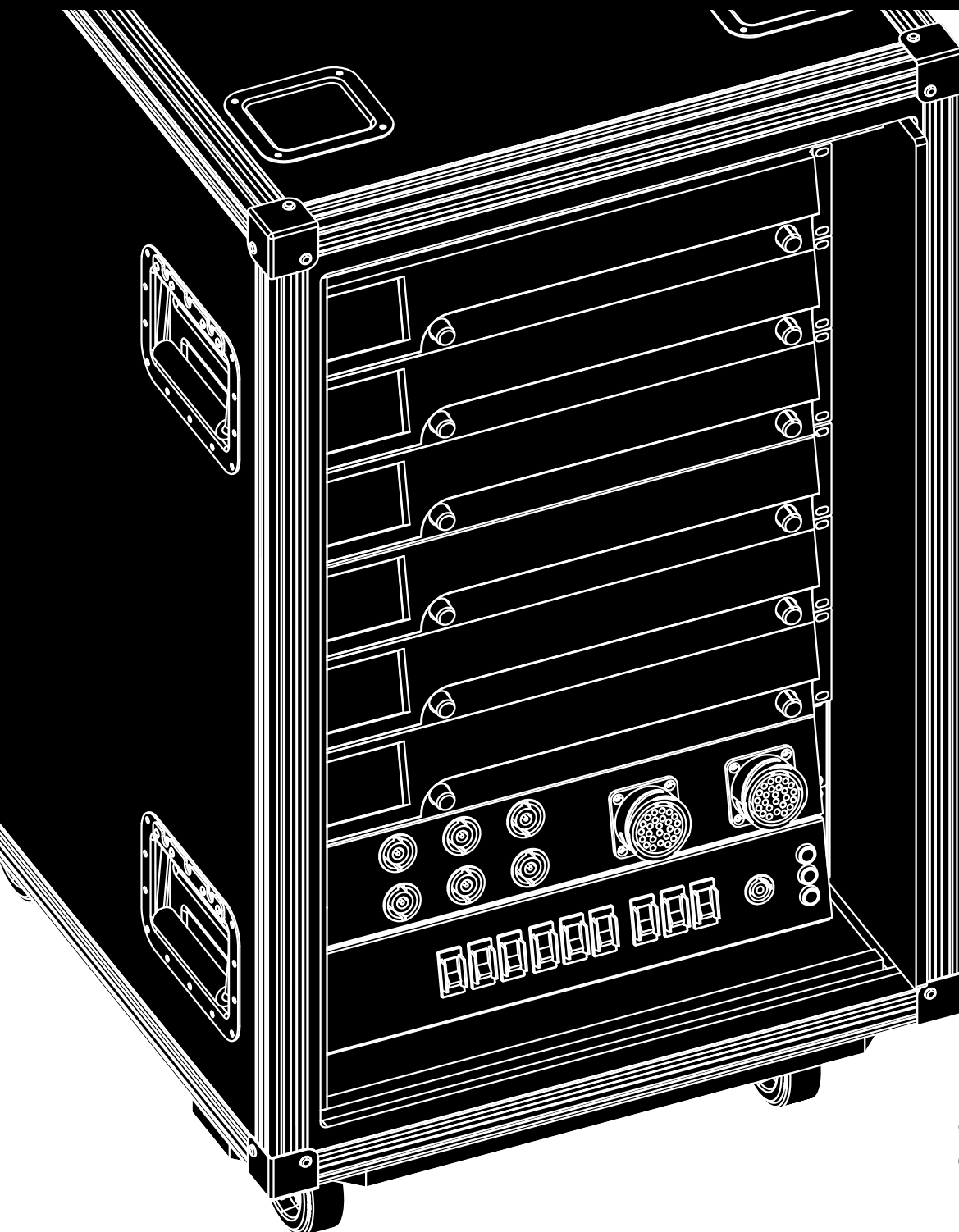

## **General information**

Z5601.002 Manual

Version: 1.2 en, 06/2022, D2761.EN .01

Copyright © 2022 by d&b audiotechnik GmbH & Co. KG; all rights reserved.

**Keep this document with the product or in a safe place so that it is available for future reference.**

We recommend you to regularly check the d&b website for the latest version of this document.

When reselling this product, hand over this document to the new owner.

If you supply d&b products, please draw the attention of your customers to this document. Enclose the relevant documents with the systems. If you require additional documents for this purpose, you can order them from d&b.

d&b audiotechnik GmbH & Co. KG  
Eugen-Adolff-Str. 134, D-71522 Backnang, Germany  
T +49-7191-9669-0, F +49-7191-95 00 00

## Explanation of graphical symbols



The lightning symbol within a triangle is intended to alert the user to the presence of uninsulated "dangerous voltages" within the unit's chassis that may be of sufficient magnitude to constitute a risk of electric shock to humans.



The exclamation point within a triangle is intended to alert the user to the presence of important operating and service instructions in the literature accompanying the product.



**Before using this product, carefully read the applicable items of the following safety instructions.**

1. Keep these instructions for future reference.
2. Read these instructions.
3. Heed all warnings.
4. Follow all instructions.
5. **WARNING!**  
To reduce the risk of fire or electric shock:
  - Do not expose the rack assembly to rain or moisture.
  - Keep water or other liquids away.
  - Do not place liquid filled containers, for example beverages, on top of the rack assembly.
  - Do not operate the rack assembly while it is wet or standing in liquid.
6. Do not use the rack assembly if its mains power cord is damaged or frayed.  
Protect the power cord from being walked upon or pinched, particularly at the plugs and the point where it exits from the rack assembly.
7. Use the mains plug of the rack assembly as the disconnecting device and keep it readily accessible.
8. Lay all cables connected to the rack assembly carefully so that they cannot be crushed by vehicles or other equipment and that no one can either step on them or trip over them.
9. Unplug the rack assembly during lightning storms or when unused for long periods of time.

|          |                                                         |           |
|----------|---------------------------------------------------------|-----------|
| <b>1</b> | <b>Z5601.002 D40 Touring rack assembly 18 RU CEE</b>    | <b>5</b>  |
| 1.1      | Intended use.....                                       | 5         |
| 1.2      | Scope of supply.....                                    | 5         |
| <b>2</b> | <b>Handling, cooling and placement</b> .....            | <b>7</b>  |
| 2.1      | Handling.....                                           | 7         |
| 2.2      | Cooling and placement.....                              | 7         |
| <b>3</b> | <b>Z5606.000 Mains power distributor 32 A CEE</b> ..... | <b>9</b>  |
| 3.1      | Intended use.....                                       | 9         |
| 3.2      | MAINS IN.....                                           | 9         |
| 3.3      | MAINS.....                                              | 10        |
| 3.4      | AUXILIARY MAINS OUTPUTS .....                           | 10        |
| <b>4</b> | <b>Z5578 LS connector panel 6 x NL8 / 2 x LKA25</b> ..  | <b>11</b> |
| 4.1      | Intended use.....                                       | 11        |
| 4.2      | 4 CH OUTPUTS.....                                       | 11        |
| 4.3      | 12 CH OUTPUT.....                                       | 12        |
| <b>5</b> | <b>Z5604 I/O Panel</b> .....                            | <b>13</b> |
| 5.1      | Intended use.....                                       | 13        |
| 5.2      | Overview.....                                           | 13        |
| 5.2.1    | INPUT.....                                              | 13        |
| 5.2.2    | INPUT LINK.....                                         | 13        |
| 5.2.3    | Remote network option.....                              | 13        |
| <b>6</b> | <b>DN1 Ethernet switch</b> .....                        | <b>14</b> |
| 6.1      | Overview.....                                           | 14        |
| 6.2      | Mains connection.....                                   | 14        |
| 6.3      | Front panel.....                                        | 14        |
| 6.3.1    | ETH 9 - ETH 11.....                                     | 14        |
| 6.3.2    | Mode selection.....                                     | 15        |
| 6.3.3    | LED indicators.....                                     | 15        |
| 6.4      | Rear panel.....                                         | 16        |
| <b>7</b> | <b>Rack wiring diagrams</b> .....                       | <b>17</b> |



# 1 Z5601.002 D40 Touring rack assembly 18 RU CEE

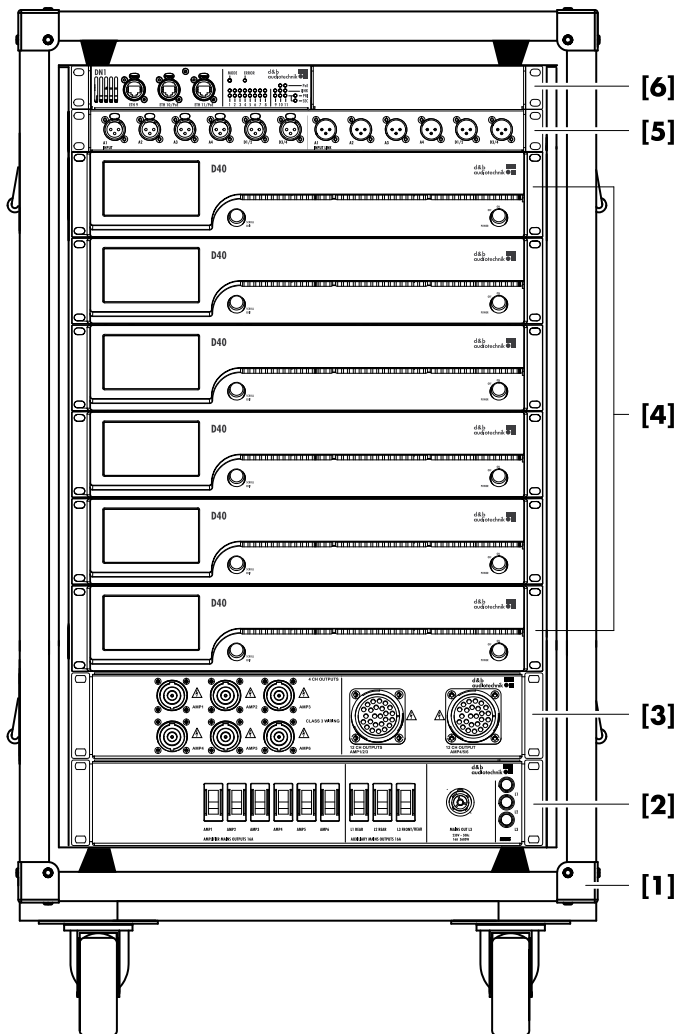
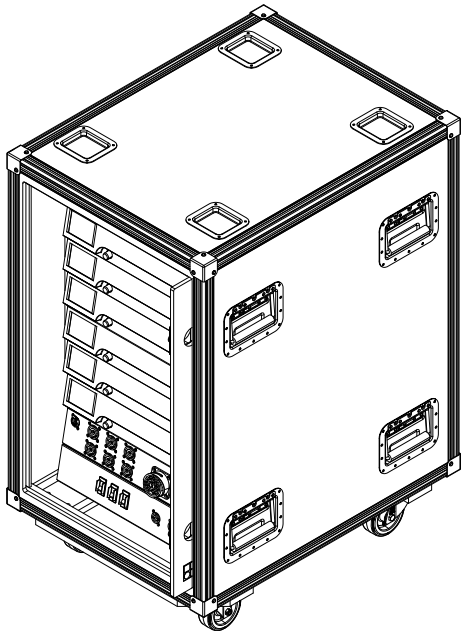

## 1.1 Intended use

The d&b Z5601.002 D40 Touring rack assembly CEE is intended for large scale mobile sound reinforcement applications. It is designed as a closed and prewired 18 RU system rack providing mains power distribution and connector interfaces for 6 x D40 amplifiers.

For this purpose, the touring rack is equipped with a 32 A CEE mains power distribution device (Z5606.000) as well as a loudspeaker connector panel (Z5578.001).

In addition, the Z4001 DN1 Ethernet network switch provides an AVB-enabled 11-port switch (3 x etherCON / 8 x RJ45).

Also incorporated is an I/O panel (Z5604), which serves as a connector interface for both analog and digital audio signals.

## 1.2 Scope of supply

Before starting up, please verify the shipment for completeness and proper condition of the items.

If there is any sign of obvious damage, do not operate the rack assembly and contact your local dealer from whom you received it.

| Pos.       | Qty. | d&b Code     | Description                                                      |
|------------|------|--------------|------------------------------------------------------------------|
| [1]        | 1    | Z5601.002    | Touring rack assembly 18 RU (CEE) - with shock mounted 19" frame |
| Including: |      |              |                                                                  |
| [2]        | 1    | Z5606.000    | Mains power distribution and LS Connector panel (CEE)            |
| [3]        | 1    | Z5578.001    | Dy LS panel                                                      |
| [4]        | 6    | Z2850        | D40 amplifier                                                    |
| [5]        | 1    | Z5604        | Dy I/O panel                                                     |
| [6]        | 1    | Z4001        | DN1 Milan network switch                                         |
| [7]        | 1    | Z5333.001    | Rack link network                                                |
|            |      | D2761.EN .01 | Z5601.002 Manual                                                 |

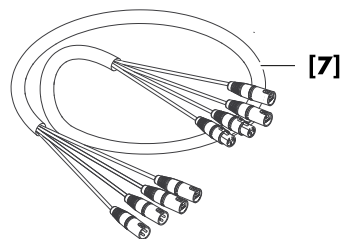

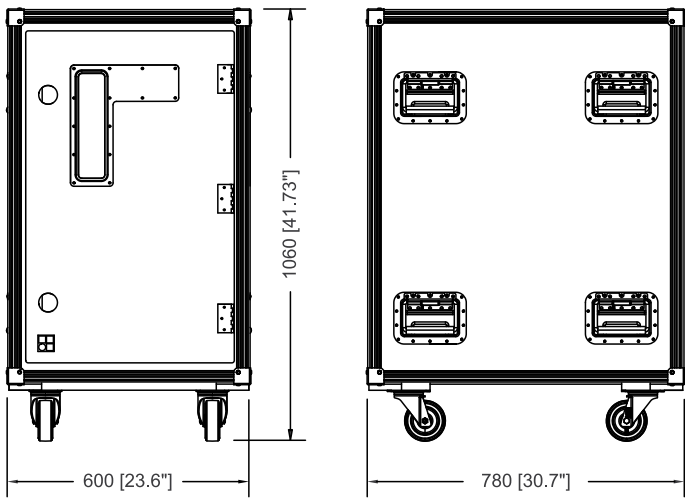

**Dimensions and weight**

Height x width x depth ..... 1060 x 600 x 780 mm  
 ..... 41.73 x 23.6 x 30.7"  
 Total weight ( 1x DN1 included) ..... 179 kg / 394 lb

## 2 Handling, cooling and placement

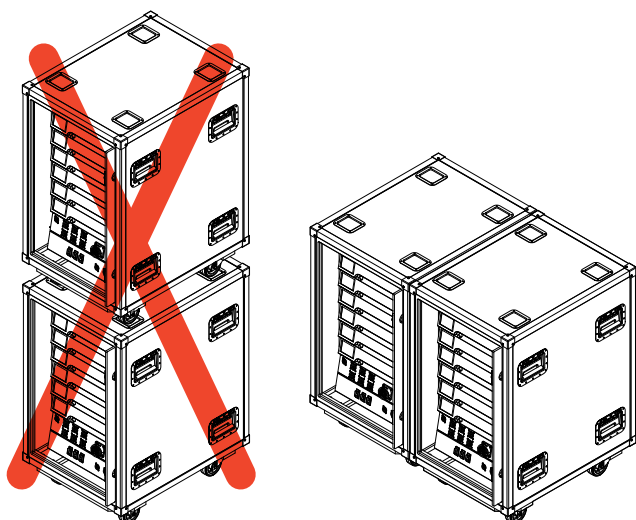
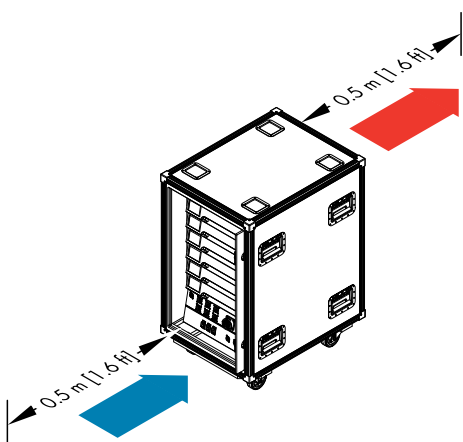
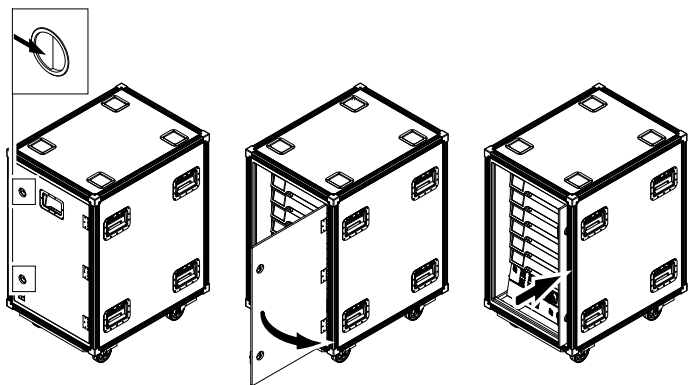

### 2.1 Handling

The touring rack is equipped with two sliding doors allowing quick and easy access to the front and rear panels of the devices.

1. Unlock the both door lock mechanisms.
2. Open the door.
3. Push the door into its park position.

### 2.2 Cooling and placement

#### NOTICE!

#### Risk of malfunction due to overheating!

**Make sure** both the front and rear doors are opened and pushed into their park positions to provide sufficient cooling.

When using the d&b Z5601.002 Touring rack assembly, make sure to provide sufficient space of 0.5 m (1.6 ft) at the front and rear of the touring rack to ensure adequate cooling airflow.



#### CAUTION!

#### Risk of personal injury and/or damage to material due to possible tipping over!

To avoid possible tipping over, do not move stacked touring racks.

Do **not stack** Z5601.002 Touring rack assemblies. The rack assemblies can be positioned side by side.

They can also be combined with Z5600 D40 or Z5560 D20 Touring rack assemblies, either side by side or with a maximum of **one** of these Touring racks positioned on top as shown in the graphic below (shown with: Z5600 D40 Touring rack assembly. The same applies to Z5560 D20 Touring rack assembly.)

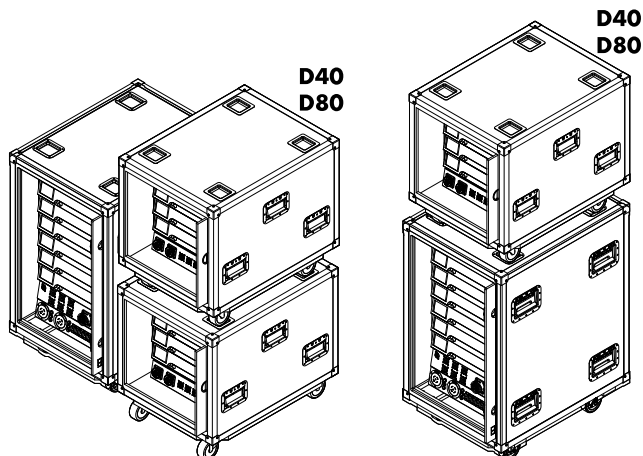

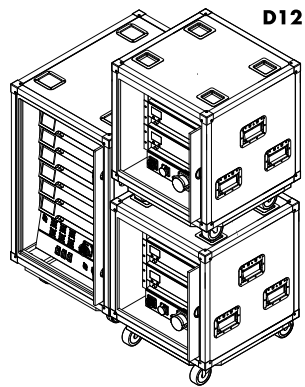
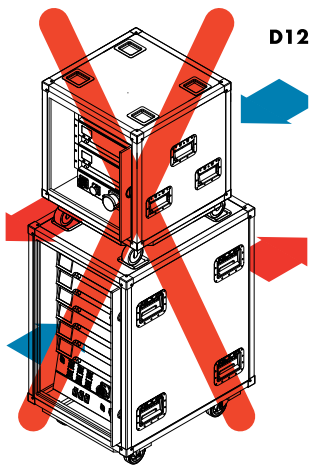

When combining Z5601.002 Touring rack assemblies with Z3010 D12 Touring rack assemblies or any other rack assembly that produces an opposing airflow, observe the following restrictions:

- Do **not stack** D12 Touring racks or any other rack assemblies with opposing airflow on top of the Z5601.002 Touring rack.
- Z5601.002 and the D12 Touring rack assemblies can be positioned side by side.

### 3 Z5606.000 Mains power distributor 32 A CEE

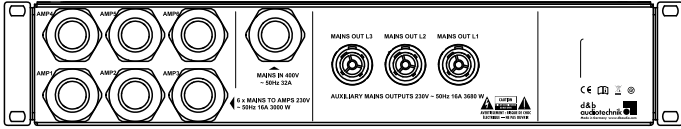

Z5606.000 Rear panel

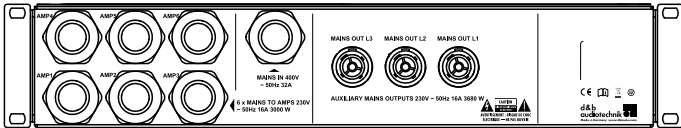

AMP1 AMP2 AMP3 AMP4 AMP5 AMP6  
AMPLIFIER MAINS OUTPUTS 16A

#### 3.1 Intended use

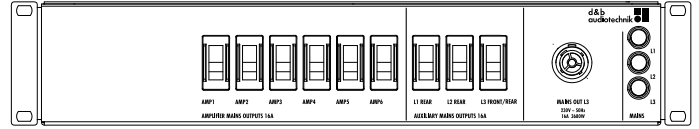

Z5606.000 Front panel

The Z5606.000 Mains power distributor is designed and dimensioned to provide and distribute the mains power supply necessary for **six** D40 amplifiers.

It is a protective class 1 unit with IP class 20 (NOT rain-, drip-, or splash-proof!).

The Z5606.000 Mains power distributor must not be used for any other purpose or outside of a system rack.

#### 3.2 MAINS IN



**WARNING!**  
**Potential risk of electric shock.**

The mains power distributor is a protective class 1 unit. A missing earth (ground) contact may cause dangerous voltages in the housing and controls and may lead to electric shock.

- Connect the unit to mains power supplies with protective earth only.
- If there is any sign of obvious damage to the power cord and/or CEE mains connector, do not use the unit and replace it before further use.
- Do not connect or disconnect the CEE mains connector under load or live.
- Please ensure the mains connector is accessible at any time to disconnect the unit in case of malfunction or danger.

Apart from the six fixed single-phase mains power lines (6 x MAINS TO AMPS 230 V) for the internal mains power supply of the amplifiers, the Z5606.000 Mains power distributor is supplied with a fixed 3-phase power cord equipped with a 32 A CEE (Cekon) mains connector.

#### Required mains supply network configuration

3-phase 230/400 VAC - 50/60 Hz - 32 A<sub>max.</sub> B or C-Frame type (3PNPE).

Connect only **one** rack assembly to the mains power outlet of the onsite sub-distribution.

Each single-phase mains power line is equipped with a dedicated circuit-breaker (16 A / B-Frame type).

The respective circuit-breakers of the onsite mains distribution are still necessary for this purpose.

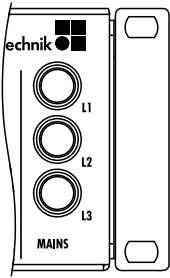

### 3.3 MAINS

When the rack is connected to the onsite mains power supply, the three mains indicators display the presence of the onsite mains supply lines (phase conductor L1-L2-L3).

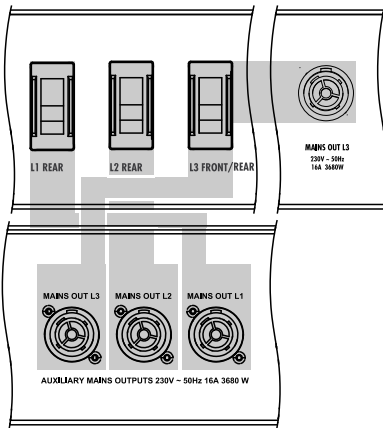

### 3.4 AUXILIARY MAINS OUTPUTS

Four auxiliary mains outputs (powerCON® TRUE 1 TOP sockets - one on the front panel and three on the rear panel) is provided.

One of these sockets is used to apply mains supply for the DN1 device.

The remaining sockets are intended for the connection of low current devices such as notebooks or additional Ethernet switches.

The sockets are equipped with dedicated circuit-breakers on the front panel (16 A / C-Frame type).

## 4 Z5578 LS connector panel 6 x NL8 / 2 x LKA25

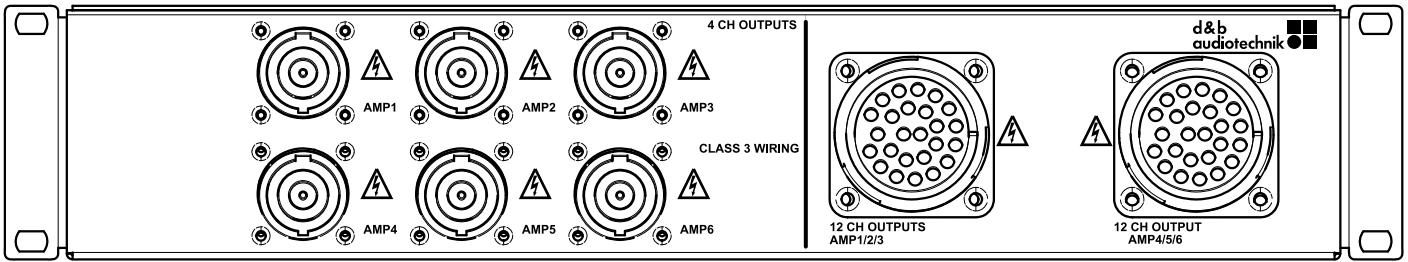

### 4.1 Intended use

The Z5578 Loudspeaker connector panel acts as a connecting interface providing all output channels of each amplifier on its dedicated NL8 socket (4 channels) and two LKA25 connector sockets (12 channels each), which directly integrate into the d&b MC24 multicore system.

It is a class 3 wiring unit with IP class 20 (NOT rain-, drip-, or splash-proof!).

The Z5578 Loudspeaker connector panel must not be used for any other purpose or outside the system rack.

### 4.2 4 CH OUTPUTS

#### NOTICE!

The 4 CH OUTPUTS connectors are only intended as an interface to loudspeaker multicores such as the d&b Z5343.xxx and breakout adapters such as the d&b Z5347.xxx.

Do not connect any loudspeaker cabinets, neither passive nor active systems, to the 4 CH OUTPUTS connectors, otherwise there is a risk of damaging the loudspeaker components or the amplifier.

Each of the 4 CH OUTPUTS connectors represents the 4 CHANNEL OUTPUT of the respective D80 amplifier.

Each connector carries the output signals of all four channels of the amplifier with the following pin assignment.

|                              |                              |
|------------------------------|------------------------------|
| 1+/- = Channel A pos. / neg. | 2+/- = Channel B pos. / neg. |
| 3+/- = Channel C pos. / neg. | 4+/- = Channel D pos. / neg. |

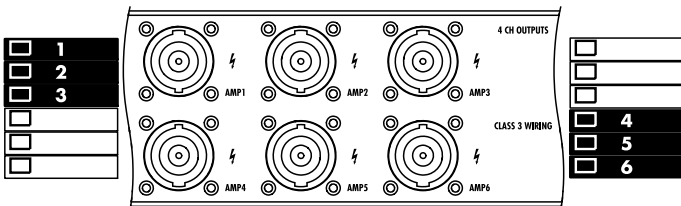

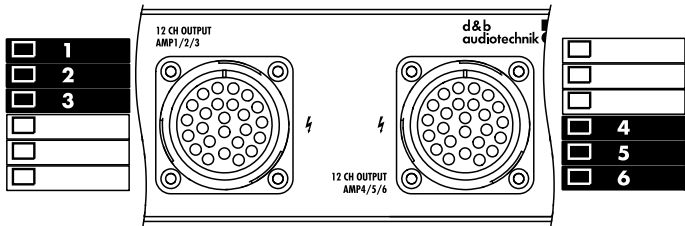

### 4.3 12 CH OUTPUT

Two 12 CH OUTPUT multipin connectors (LKA25) are provided to allow efficient system wiring using the d&b MC24 multicore system (Z5328.xxx MC24 LKA25 F/M Multicore, Z5325.000 Break-out adapter LKA25M to 6 x NLT4M, Z5327.000 Break-out adapter LKA25M to 12 x NLT4M and Z5326.000 Break-in adapter 3 x NLT8F to LKA25F).

The d&b MC24 Multicore System combines a 12-amplification-channels (24 lines 4 mm<sup>2</sup>) cable with an LKA25 F/M connector

For this reason, each connector of the loudspeaker connector panel carries the output signal of twelve (12) amplifier channels.

The assignment of the respective amplifiers to the corresponding connector is shown in the graphic opposite.

Pin equivalents of the LKA25 connectors and the corresponding 4 CHANNEL OUTPUT (NL8) connector of the respective amplifier are listed in the following table:

| 12 CH OUTPUT<br>AMP 1/2/3 |     |                                                                                                                                                                       |
|---------------------------|-----|-----------------------------------------------------------------------------------------------------------------------------------------------------------------------|
| LKA25                     | NL8 | Amplifier                                                                                                                                                             |
| A                         | 1+  | <b>AMP 1</b><br><input checked="" type="checkbox"/> 1<br><input type="checkbox"/><br><input type="checkbox"/><br><input type="checkbox"/><br><input type="checkbox"/> |
| B                         | 1-  |                                                                                                                                                                       |
| C                         | 2+  |                                                                                                                                                                       |
| D                         | 2-  |                                                                                                                                                                       |
| E                         | 3+  |                                                                                                                                                                       |
| F                         | 3-  |                                                                                                                                                                       |
| G                         | 4+  |                                                                                                                                                                       |
| H                         | 4-  |                                                                                                                                                                       |
| I                         | 1+  | <b>AMP 2</b><br><input type="checkbox"/><br><input checked="" type="checkbox"/> 2<br><input type="checkbox"/><br><input type="checkbox"/><br><input type="checkbox"/> |
| J                         | 1-  |                                                                                                                                                                       |
| K                         | 2+  |                                                                                                                                                                       |
| L                         | 2-  |                                                                                                                                                                       |
| M                         | 3+  |                                                                                                                                                                       |
| N                         | 3-  |                                                                                                                                                                       |
| O                         | 4+  |                                                                                                                                                                       |
| P                         | 4-  |                                                                                                                                                                       |
| Q                         | 1+  | <b>AMP 3</b><br><input type="checkbox"/><br><input type="checkbox"/><br><input checked="" type="checkbox"/> 3<br><input type="checkbox"/><br><input type="checkbox"/> |
| R                         | 1-  |                                                                                                                                                                       |
| T                         | 2+  |                                                                                                                                                                       |
| U                         | 2-  |                                                                                                                                                                       |
| V                         | 3+  |                                                                                                                                                                       |
| W                         | 3-  |                                                                                                                                                                       |
| X                         | 4+  |                                                                                                                                                                       |
| Y                         | 4-  |                                                                                                                                                                       |

| 12 CH OUTPUT<br>AMP 4/5/6 |     |                                                                                                                                                                       |
|---------------------------|-----|-----------------------------------------------------------------------------------------------------------------------------------------------------------------------|
| LKA25                     | NL8 | Amplifier                                                                                                                                                             |
| A                         | 1+  | <b>AMP 4</b><br><input type="checkbox"/><br><input type="checkbox"/><br><input checked="" type="checkbox"/> 4<br><input type="checkbox"/><br><input type="checkbox"/> |
| B                         | 1-  |                                                                                                                                                                       |
| C                         | 2+  |                                                                                                                                                                       |
| D                         | 2-  |                                                                                                                                                                       |
| E                         | 3+  |                                                                                                                                                                       |
| F                         | 3-  |                                                                                                                                                                       |
| G                         | 4+  |                                                                                                                                                                       |
| H                         | 4-  |                                                                                                                                                                       |
| I                         | 1+  | <b>AMP 5</b><br><input type="checkbox"/><br><input type="checkbox"/><br><input type="checkbox"/><br><input checked="" type="checkbox"/> 5<br><input type="checkbox"/> |
| J                         | 1-  |                                                                                                                                                                       |
| K                         | 2+  |                                                                                                                                                                       |
| L                         | 2-  |                                                                                                                                                                       |
| M                         | 3+  |                                                                                                                                                                       |
| N                         | 3-  |                                                                                                                                                                       |
| O                         | 4+  |                                                                                                                                                                       |
| P                         | 4-  |                                                                                                                                                                       |
| Q                         | 1+  | <b>AMP 6</b><br><input type="checkbox"/><br><input type="checkbox"/><br><input type="checkbox"/><br><input type="checkbox"/><br><input checked="" type="checkbox"/> 6 |
| R                         | 1-  |                                                                                                                                                                       |
| T                         | 2+  |                                                                                                                                                                       |
| U                         | 2-  |                                                                                                                                                                       |
| V                         | 3+  |                                                                                                                                                                       |
| W                         | 3-  |                                                                                                                                                                       |
| X                         | 4+  |                                                                                                                                                                       |
| Y                         | 4-  |                                                                                                                                                                       |



**5.1 Intended use**

The D40 I/O Panel is intended for rack mounting only and must not be used stand-alone outside of a rack.

Within an amplifier system rack, it acts as connecting interface for both analog and digital audio INPUT and INPUT LINK connectors.

**5.2 Overview**

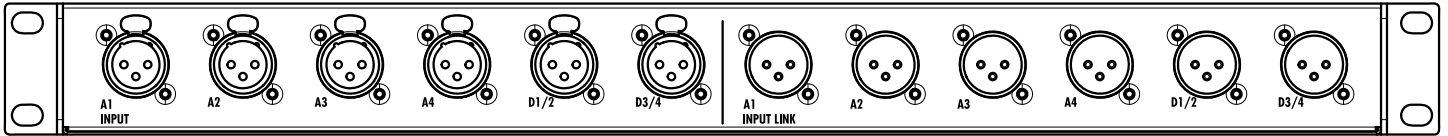

Z5604 Front view

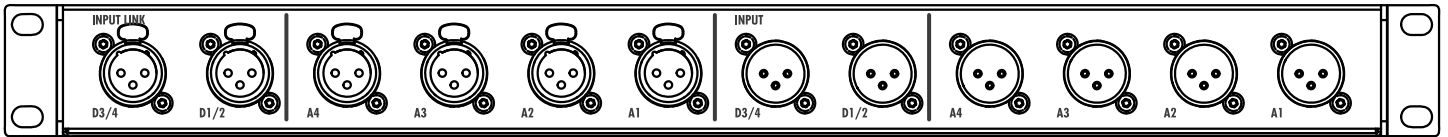

Z5604 Rear view

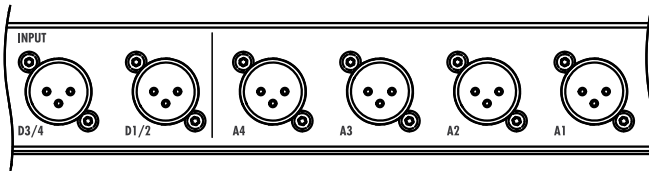
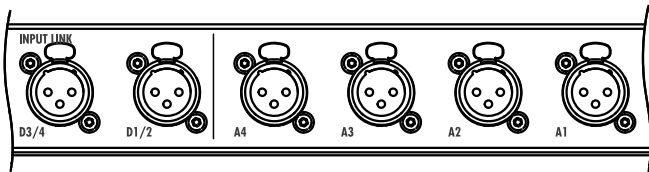

**5.2.1 INPUT**

The INPUT section represents the input connectors of the first amplifier while the other two (five) amplifiers are linked within the rack. The INPUT section allows both analog and digital audio signals to be fed to the amplifier.

**5.2.2 INPUT LINK**

The INPUT LINK section represents the link output connectors of the last (third/sixt) amplifier and allows the linking of further system racks.

**5.2.3 Remote network option**

You can daisy chaining the rack assemblies within a remote network using the enclosed rack link cable (Z5333.001).

For remote purposes via Ethernet/OCA, it is strongly recommended to use the prewired configuration in combination with the DN1 when linking entire rack assemblies, as shown in the graphic opposite. It is recommended to link a maximum of up to 6 rack assemblies in this way.

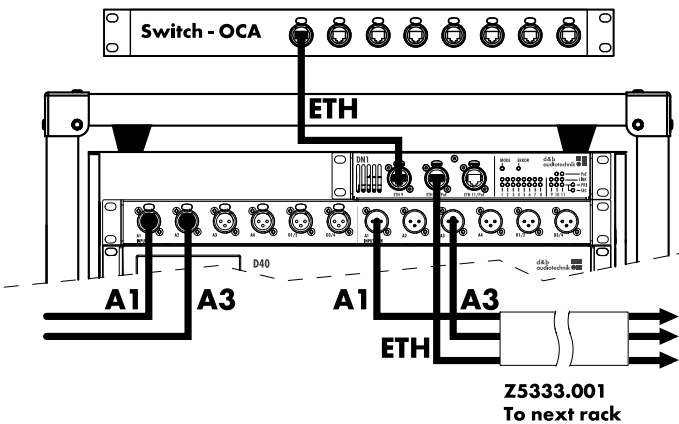

I/O panel, rack link example:  
2ch Analog audio and Ethernet/OCA

## 6 DN1 Ethernet switch

### Rear panel connectors

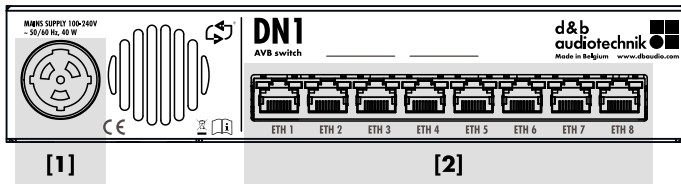

- [1] powerCON TRUE 1 TOP® mains connector socket.  
Refer to ⇒ Chapter 6.2 "Mains connection" on page 14.
- [2] Ethernet switch with 8 x RJ45 ports.  
Refer to ⇒ Chapter 6.4 "Rear panel" on page 16.

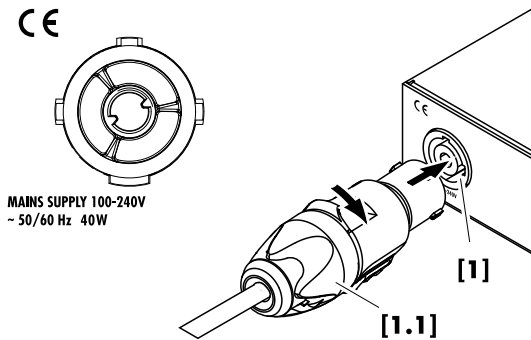

### 6.1 Overview

#### Front panel connectors, controls and indicators

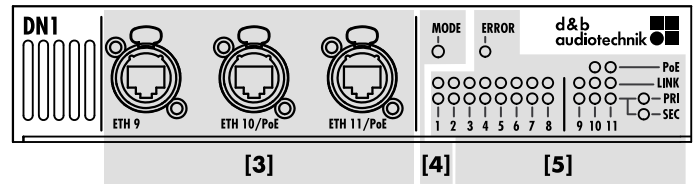

- [3] etherCON® switch ports ETH 9 - ETH 11.  
Refer to ⇒ Chapter 6.3.1 "ETH 9 - ETH 11" on page 14.
- [4] Mode button.  
Refer to ⇒ Chapter 6.3.2 "Mode selection" on page 15.
- [5] Multi-colored LED indicators.  
Refer to ⇒ Chapter 6.3.3 "LED indicators" on page 15.

### 6.2 Mains connection



The device is a protective class 1 unit. A missing earth (ground) contact may cause dangerous voltages in the housing and controls and may lead to electric shock.

- Connect the unit to mains power supplies with protective earth only.
- If there is any sign of obvious damage to the power cord and/or mains connector, do not use the power cord and replace it before further use.
- Please ensure the mains connector is accessible at any time to disconnect the unit in case of malfunction or danger.

Before connecting the device to mains voltage, check that the mains voltage and frequency correspond to the specifications on the rating label above the mains connector socket on the rear panel of the unit.

A mains connector socket [1] is fitted on the rear panel and an appropriate power cord [1.1] is supplied.

### 6.3 Front panel

#### 6.3.1 ETH 9 - ETH 11

The DN1 device provides an 11-port Ethernet switch for different network topologies, redundancy (max. two devices) and advanced functionality with AVB. Three connectors are provided on the front panel.

#### Power over Ethernet

The « ETH 10/PoE » and « ETH 11/PoE » Ethernet connectors also provide Power over Ethernet based on IEEE standard 802.3af. Each port delivers a maximum of 15.4 W, both ports deliver a maximum total of 25 W. If the maximum power is exceeded, PoE supply will be shut off.

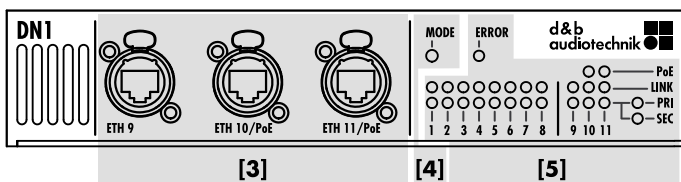

**Note:** Either of the « ETH 10/PoE » or « ETH 11/PoE » connector is also intended to feed an inclinometer such as the d&b ArraySight sender unit, which is integrated in the flying frame for vertical aiming of the entire array.

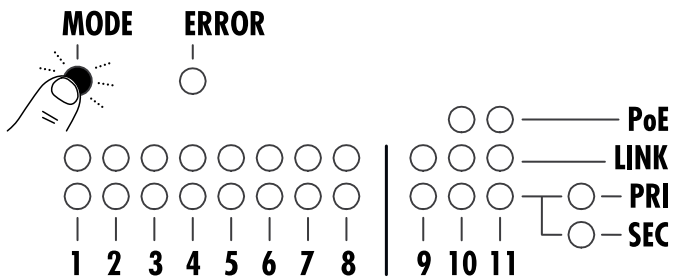

### Reset mode

The remote reset function resets all settings related to remote communication to factory defaults. To reset the DN1 device to defaults, proceed as follows:

1. Select and hold the «MODE» button for five seconds.
  - ↳ All AVB port status LEDs turn red for two seconds. All other LEDs are off.
2. Release the «MODE» button.
3. Within two seconds, select the «MODE» button once again.
  - ↳ All AVB port status LEDs turn red for two seconds. All other LEDs are off. All remote settings are set to default.

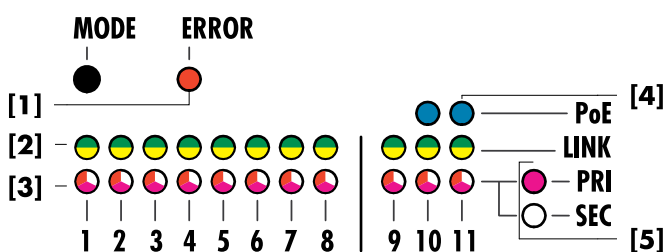

### 6.3.2 Mode selection

The DN1 device features a «MODE» button on the front panel. This button is used for three different purposes:

- **Configuration mode**  
Toggle between primary and secondary configurations.
- **Reset mode**  
Reset the device to remote settings default.
- **Wink mode** (device identification)  
Visual identification of your device.

#### Configuration mode

If the DN1 device is operated within an AVB network, you must configure all switches for use in a primary or secondary network. The DN1 recognizes a primary or secondary connection of the connected AVB device and indicates an error if a primary port has been connected to a secondary switch and vice versa.

To enter the Configuration mode, proceed as follows:

1. Select and hold the «MODE» button for two seconds.
  - ↳ Either the «PRI» or the «SEC» LED starts to flash in periods of one second with an uptime of 50%.
2. Select the «MODE» button to toggle between primary and secondary configurations.
  - ↳ After five seconds of inactivity, the «PRI» and «SEC» LEDs leave the Configuration mode and switch back to normal display mode.

**Note:** Without an DHCP server in LinkLocal IP mode:

- IP address range in primary mode: 169 . 254 . xxx
- IP address range in secondary mode: 172 . 31 . xxx

#### Wink mode (device identification)

To activate the Wink mode, proceed as follows:

1. Select the «MODE» button once.
  - ↳ All AVB port status LEDs flash in the color of the current Configuration mode (● = Primary / ○ = Secondary).
2. After three seconds, the Wink mode stops automatically.

### 6.3.3 LED indicators

All device states and operating modes are indicated by dedicated multi-colored LEDs.

**Note:** In case of an device error, connect the device to R1 via OCA to obtain further information.

The LED color codes and the related device states and operating modes are detailed in the table below.

| LED color    | [1] Error             | [2] LINK                         | [3] AVB                                                 | [4] PoE                         | [5] PRI / SEC              |
|--------------|-----------------------|----------------------------------|---------------------------------------------------------|---------------------------------|----------------------------|
| ●            | Device error detected | -                                | Detected AVB network does not match the device settings | -                               | -                          |
| ●            | -                     | Network activity, max. 1 Gbit    | -                                                       | -                               | -                          |
| ●            | -                     | Network activity, max. 100 Mbit. | -                                                       | -                               | -                          |
| ●            | -                     | -                                | Primary AVB network detected                            | -                               | Device in PRI network mode |
| ○            | -                     | -                                | Secondary AVB network detected                          | -                               | Device in SEC network mode |
| ●            | -                     | -                                | -                                                       | Active PoE supply               | -                          |
| LED off      | Normal operation      | No active connection             | No AVB network information                              | No PoE enabled device connected | -                          |
| LED flashing |                       | Traffic                          |                                                         | PoE Error                       |                            |

## 6.4 Rear panel

### ETH 1 - ETH 8

The DN1 device provides a RJ45 8-port panel at the rear of the device.

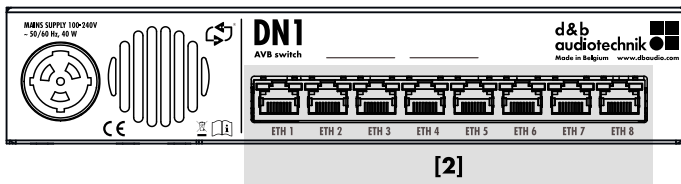

## 7 Rack wiring diagrams

### Mains power connection and internal mains supply distribution

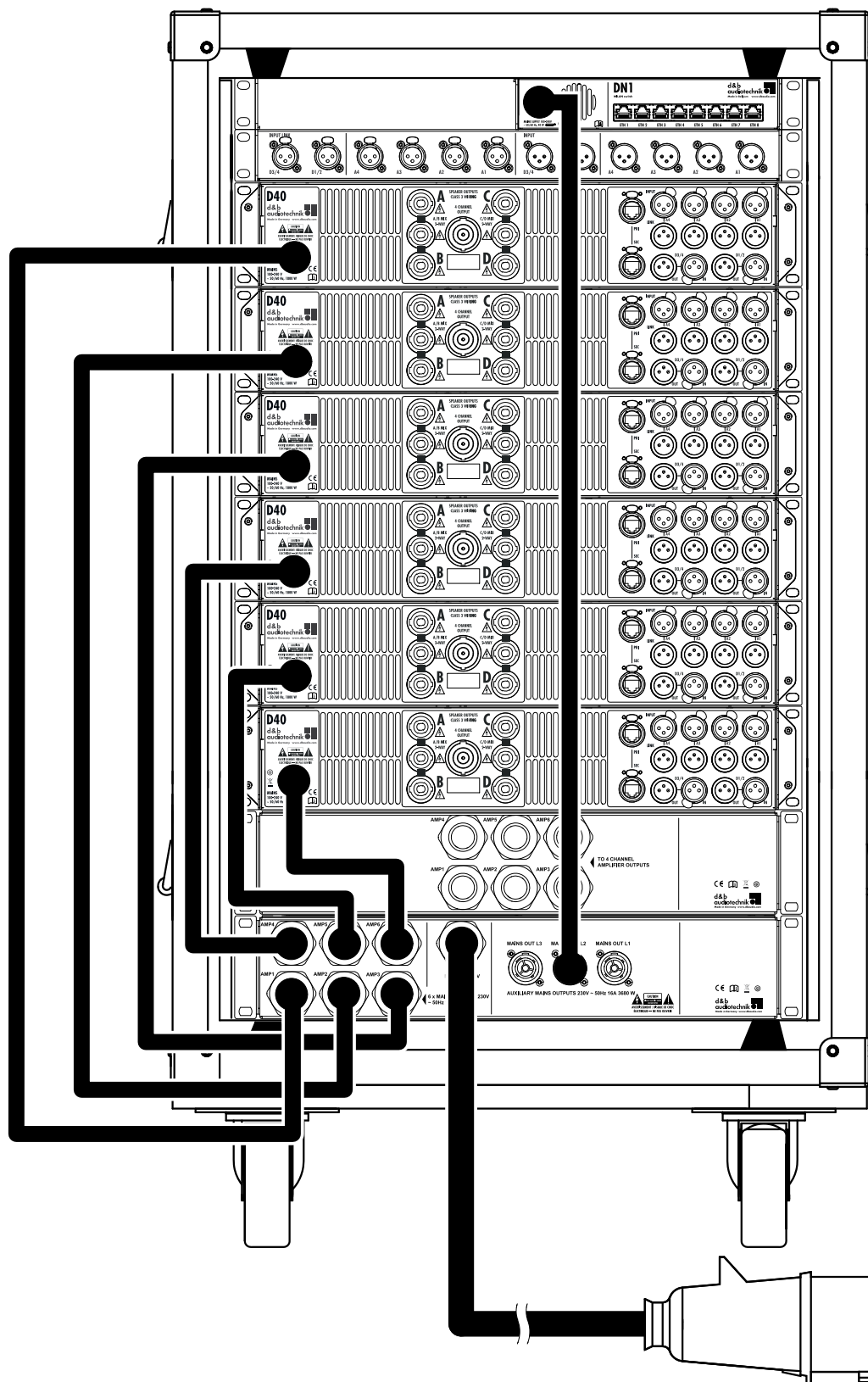

## Internal 4 CHANNEL OUTPUT wiring

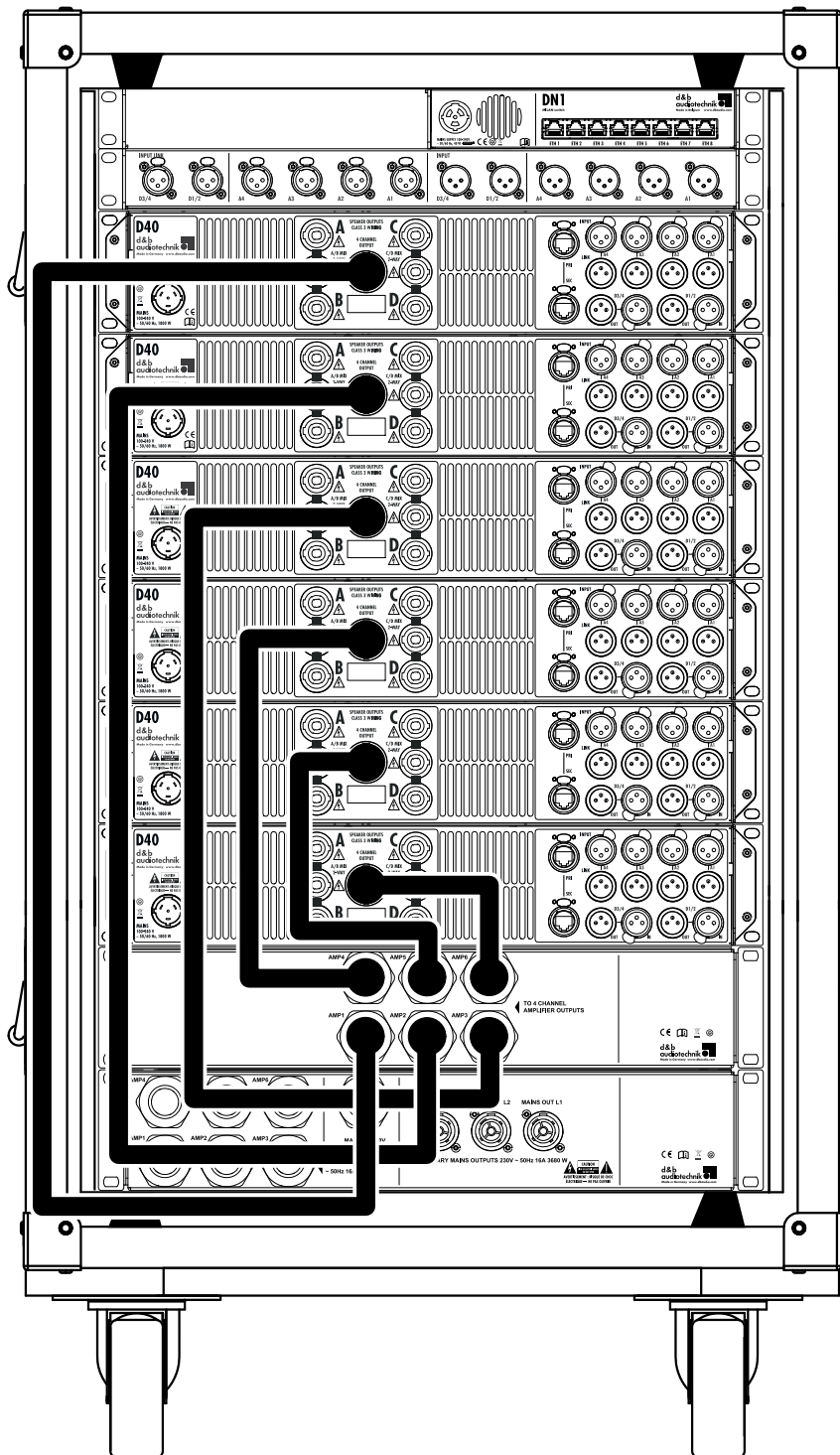

## Internal analog audio INPUT and LINK wiring

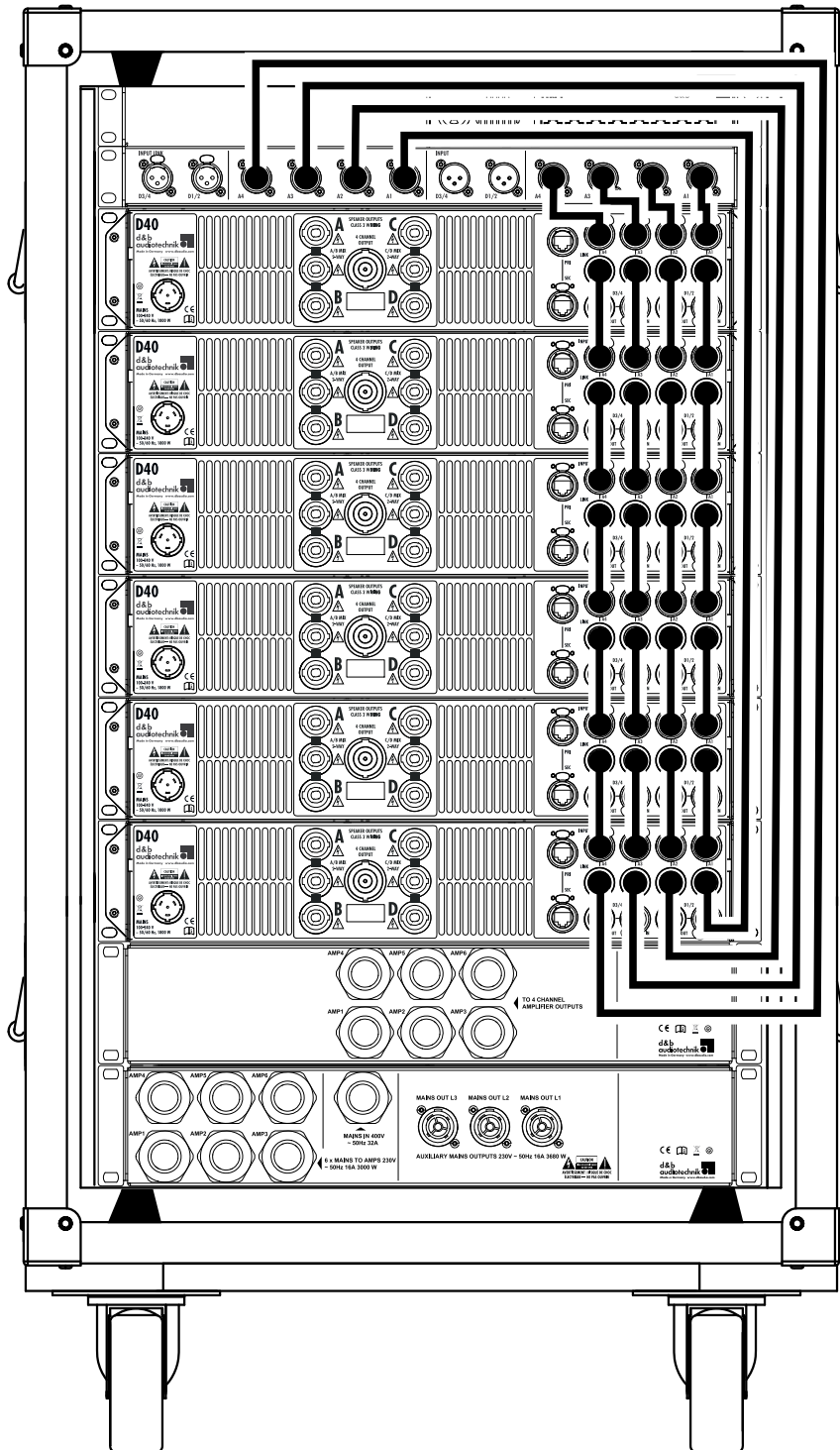



## Internal digital audio INPUT and LINK wiring

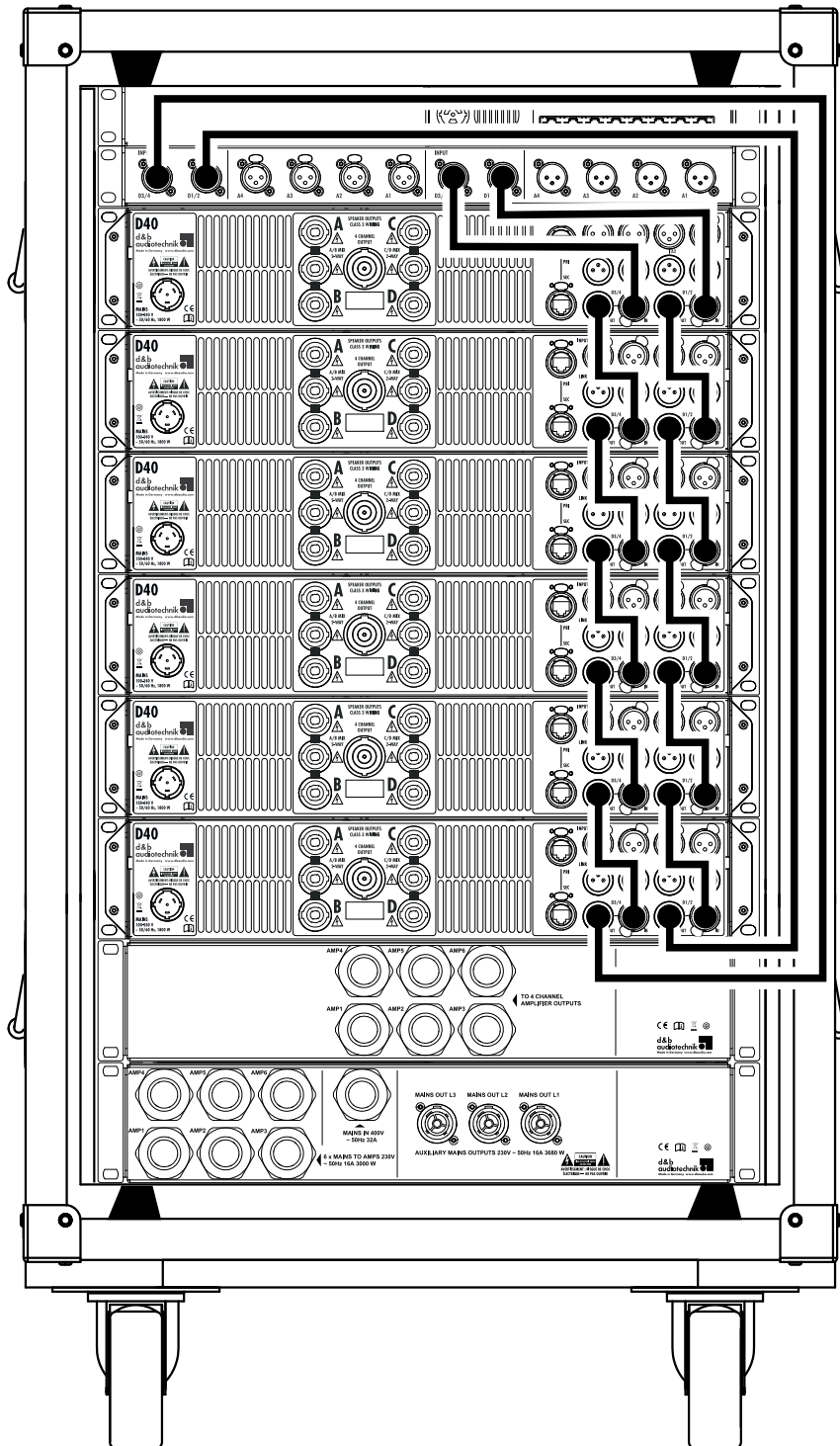



## Internal Ethernet network wiring

