

Z

44S Accessories Mounting instructions 1.2 en

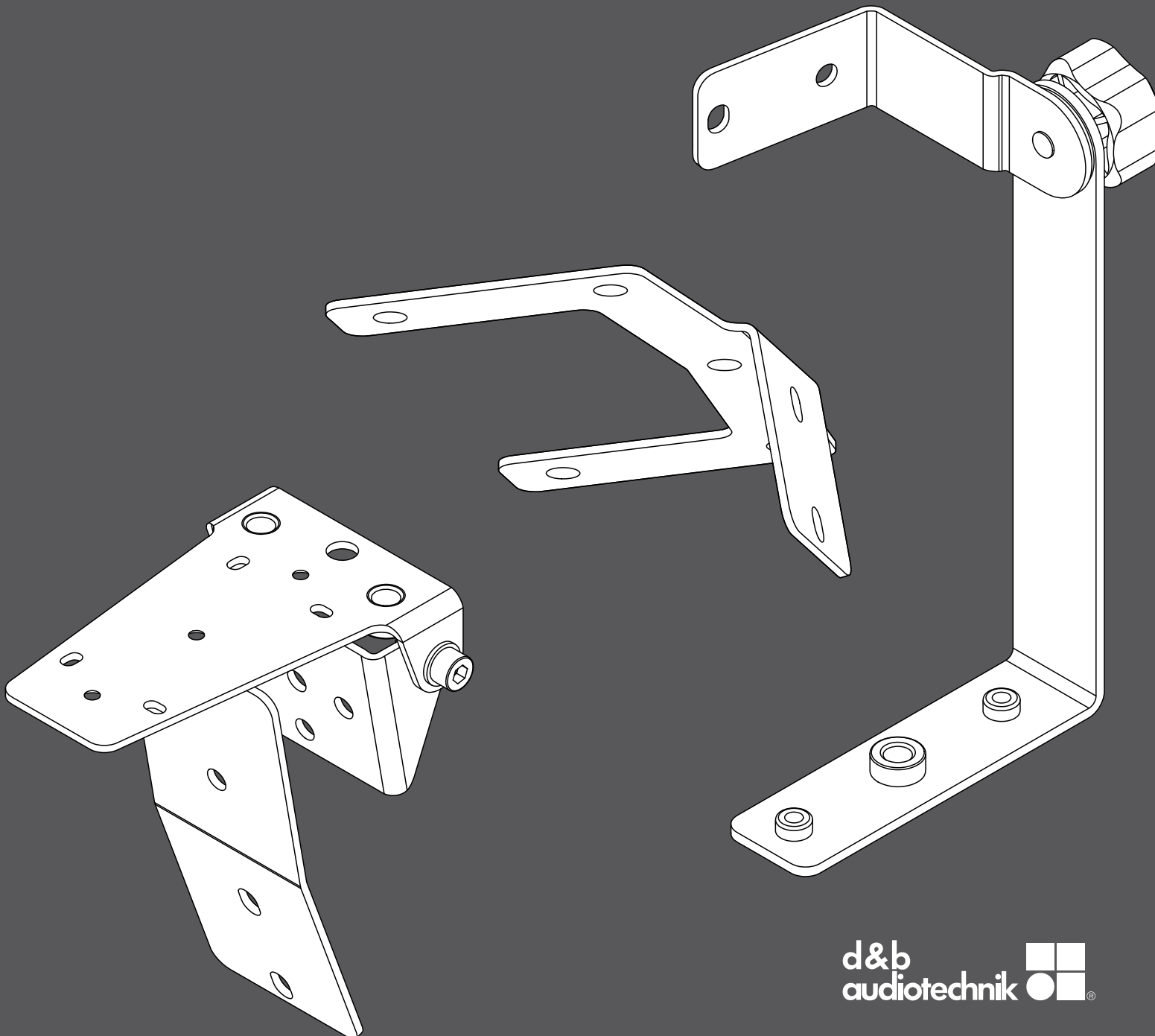

General information

44S Accessories Mounting instructions

Version: 1.2 en, 03/2022, D2634.EN .01

Copyright © 2022 by d&b audiotechnik GmbH & Co. KG; all rights reserved.

Keep this document with the product or in a safe place so that it is available for future reference.

We recommend you to regularly check the d&b website for the latest version of this document.

When reselling this product, hand over this document to the new owner.

d&b audiotechnik GmbH & Co. KG
Eugen-Adolff-Str. 134, D-71522 Backnang, Germany
T +49-7191-9669-0, F +49-7191-95 00 00
docadmin@dbaudio.com, www.dbaudio.com

1	44S Accessories	4
1.1	Intended use.....	4
1.1.1	Safety precautions.....	4
2	Z5423 44S Mounting bracket/Z5425 44S Cluster bracket	5
2.1	Scope of supply and weight.....	5
2.2	Mounting options and angle settings.....	5
2.3	Assembly.....	6
2.4	Z5425 Cluster bracket option.....	6
2.4.1	Cluster assembly.....	7
2.5	Z5354 E8/E12 Flying adapter option.....	8
2.6	Z5423 Fixing template.....	8
3	Z5424 44S L-mount adapter	9
3.1	Scope of supply and weight.....	9
3.2	Mounting options and angle settings.....	9
3.3	Assembly.....	9
3.4	Z5424 Fixing template.....	10
4	Z5426 44S Swivel bracket	11
4.1	Scope of supply and weight.....	11
4.2	Mounting options and angle settings.....	11
4.3	Assembly.....	12
5	Manufacturer's declarations	13
5.1	Conformity of rigging components.....	13
5.2	Disposal.....	13

1 44S Accessories

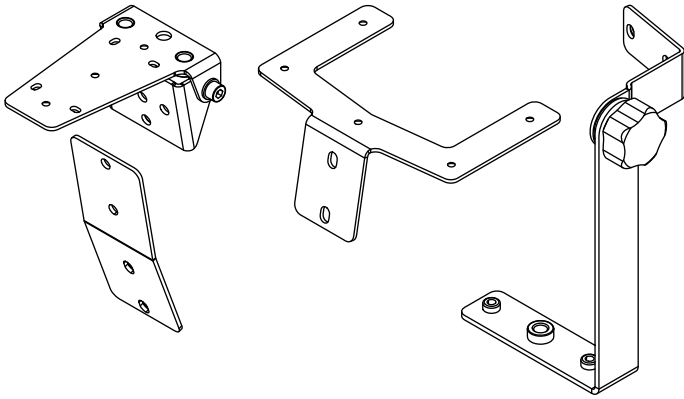

44S accessories

From left to right... :

- **Z5423/Z5425** 44S Mounting bracket/44S Cluster bracket
- **Z5424** 44S L-mount adapter
- **Z5426** 44S Swivel bracket

1.1 Intended use

The d&b 44S accessories must only be used in connection with the d&b 44S loudspeaker, as described in these mounting instructions.

NOTICE!

Observe the maximum permitted load of the individual accessories, as indicated in these mounting instructions.

1.1.1 Safety precautions

- Installation and setup should only be carried out by qualified and authorized personnel observing the valid national Rules for the Prevention of Accidents (RPA).
- It is the responsibility of the person installing the assembly to ensure that the suspension/fixing points are suitable for the intended use.
- Always carry out a visual and functional inspection of the items before use. In case there is any doubt as to the proper functioning and safety of the items, these must be withdrawn from use immediately.

All system components must be inspected for faults before use. Damaged components must be withdrawn from use immediately.

Rigging examples

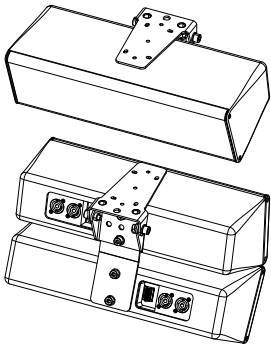

Z1650 44S loudspeaker with:

- **Z5423** 44S Mounting bracket
- **Z5425** 44S Cluster bracket

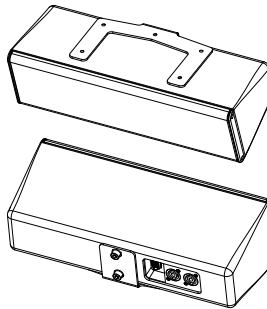

Z1650 44S loudspeaker with:

- **Z5424** 44S L-mount adapter

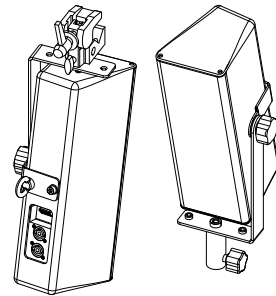

Z1650 44S loudspeaker with:

- **Z5426** 44S Swivel bracket
- **E6532** Super clamp
- **Z5034** Stand adapter M10

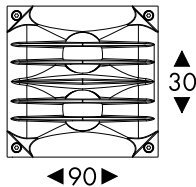

HF dispersion of the loudspeaker

Depending on the application (horizontal or vertical deployment), please observe the correct orientation of the HF horn of the loudspeaker ⇒ HF dispersion.

To change the horn orientation, please refer to the 44S manual which is provided with the loudspeaker or can be downloaded from the relevant product page at www.dbaudio.com.

2 Z5423 44S Mounting bracket/Z5425 44S Cluster bracket

2.1 Scope of supply and weight

Please verify the shipment for completeness and proper condition of the items.

Z5423

Qty.	d&b Code	Description
1	Z5423	44S Mounting bracket [1] consisting of the base plate [1a] and the hinge plate [1b]
Including:		
2		U washer 8.4 [2]
2		Fixing screw M8 x 20 mm/ Torx #T45 [3]
1	D2634.EN .01	44S Accessories Mounting instructions

Weight (incl. all items) 1.2 kg (2.6 lb)

Z5425

Qty.	d&b Code	Description
1	Z5425	Cluster bracket 44S[1]
Including:		
2		U washer 8.4 [2]
2		Fixing screw M8 x 20 mm/ Torx #T45 [3]
1	D2634.EN .01	44S Accessories Mounting instructions

Weight (incl. all items) 0.9 kg (2 lb)

2.2 Mounting options and angle settings

The Z5423 Mounting bracket is designed as a hinge unit (base plate [1a] and hinge plate [1b]) and allows a single 44S cabinet to be mounted to ceilings or walls or any other suitable surface, either horizontally or vertically.

Due to the hinge unit, the cabinet can be continuously aligned within a certain range, either horizontally or vertically, depending on its deployment.

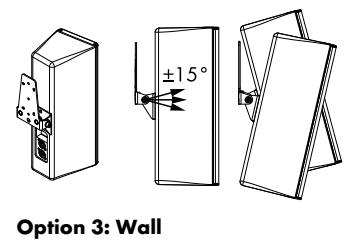
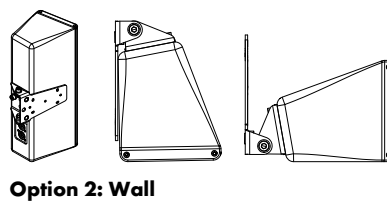
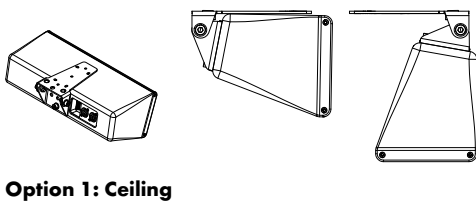
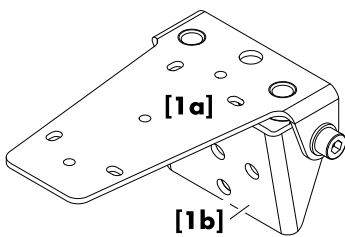
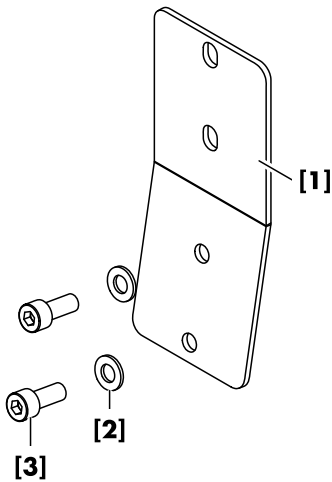
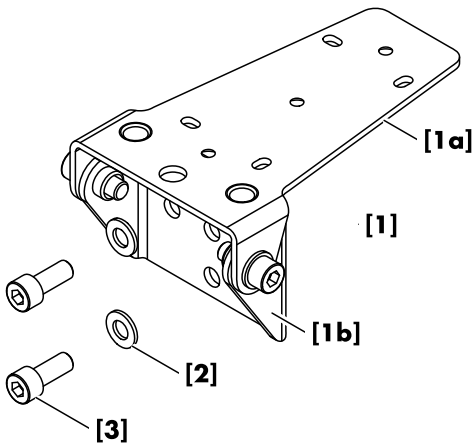

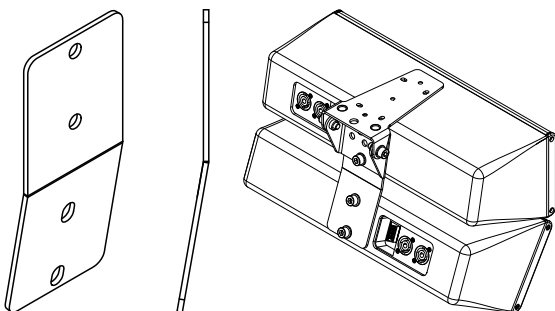
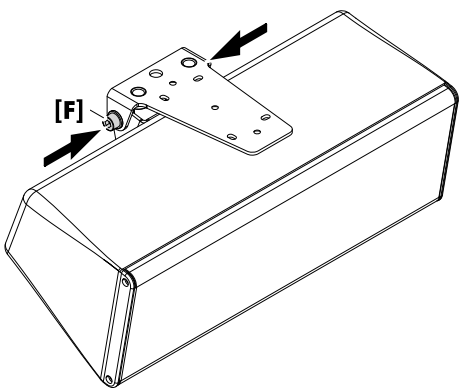
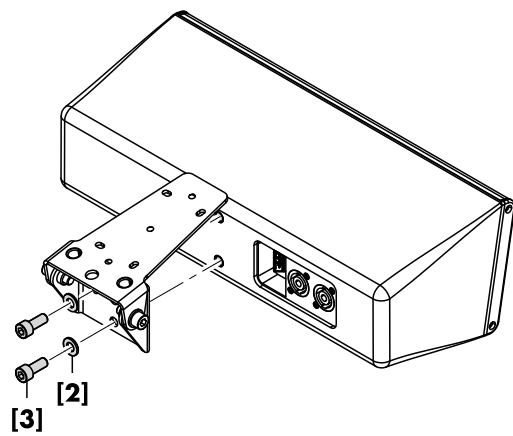
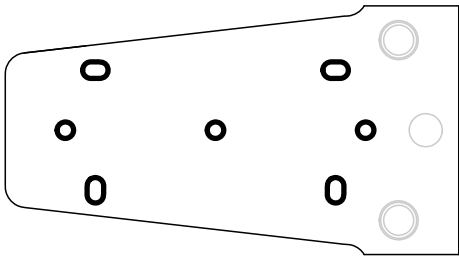

2.3 Assembly

Attaching the bracket to ceilings or walls

NOTICE!

Only use mounting parts (fixing anchors and screws) that are suitable for the intended application.

To attach the bracket to walls or ceilings, use the holes shown in the graphic opposite to provide adequate support.

A corresponding fixing template is provided in these mounting instructions (please refer to ⇒ Chapter 2.6 "Z5423 Fixing template" on page 8).

Attaching the cabinet to the bracket

NOTICE!

Only use the supplied and specified screws [3], otherwise there is a risk of damaging the threaded inserts.

Always use the U washers [2] to prevent the bolts from slackening.

Tools required:

- Torque wrench (torx size #T45)

1. Once the bracket is fixed in its operating position, attach the cabinet to the bracket.
2. Insert the screws [3] together with the U washers [2].
3. Tighten the screws with a maximum torque of 4 N·m.

Alignment (vertical)

The cabinet can be continuously vertically aligned. For this purpose, proceed as follows:

Tools required:

- Torx wrench (size #T45)

1. Slightly slacken the two fixing screws [F] (clamping screws) on both sides.
2. Align the cabinet as required.
3. Retighten both fixing screws.

2.4 Z5425 Cluster bracket option

The Z5425 Cluster bracket serves to attach a second 44S cabinet to build a 90° x 60° (h x v) cluster.

For this purpose, the bracket provides a fixed angle of 10° resulting in a splay angle of 30° between the two cabinets. Applying these angles will produce the desired total vertical coverage of 60°.

2.4.1 Cluster assembly

Due to the compact size and light weight of the cabinets, the cluster assembly can be carried out on the ground. As a next step, the entire cluster is attached to the base plate of the mounting bracket which is already fixed in its operating position.

For this purpose, proceed as follows:

Tools required:

- Torx wrench (size #T45)

1. Separating the mounting bracket

1. Slacken and undo the two fixing screws **[F]** (clamping screws) together with the U washers **[U]** and separate the items.
2. Mount the base plate to the desired operating position.

2. Assembling the cluster

Note: Observe the correct opposite orientation of the cabinets, which can be seen by the connector panels, as shown in the graphics opposite.

The best way to assemble the cabinets is to place them on their side panels.

1. Attach the cluster bracket together with the hinge plate of the mounting bracket to the first cabinet.
2. Insert the two fixing screws **[3]** together with the U washers **[2]**.
3. Tighten the screws with a maximum torque of 4 N·m.
4. Attach the second cabinet to the cluster bracket in the same manner.

3. Attaching the cluster to the base plate

1. Attach the entire cluster to the base plate **[1a]**.
2. Insert the two fixing screws **[F]** (clamping screws) together with the U washers **[U]**.
3. Set the desired vertical aiming and tighten the fixing screws.

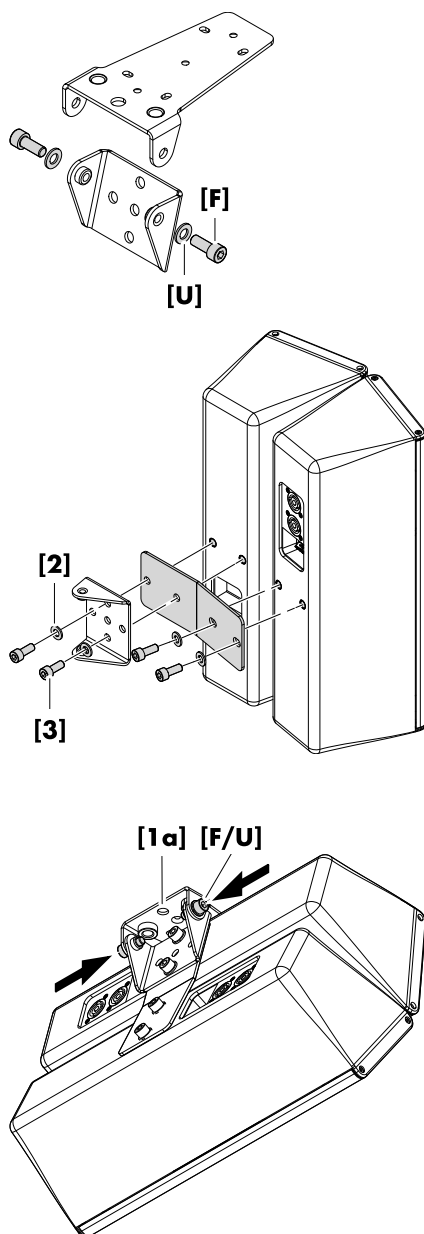

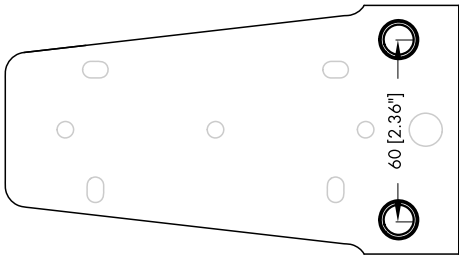

2.5 Z5354 E8/E12 Flying adapter option

The base plate of the mounting bracket is equipped with two threaded inserts M10 enabling the use of the d&b Z5354 E8/E12 Flying adapter as a suspension device.

- The adapter allows single pickpoint suspension from overhead bars or truss with a tube diameter of up to 70 mm (2.75") using the d&b Z5015 TV spigot 02 together with the d&b Z5012 Pipe clamp.
- Alternatively, the d&b E6507 1t shackle can be used for either single or dual pickpoint suspension using appropriate steel wire ropes.

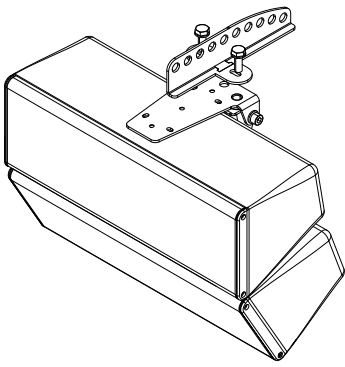

Z5354 Assembly

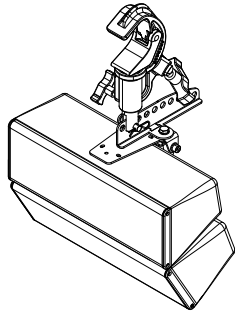

Z5015/Z5012 Assembly

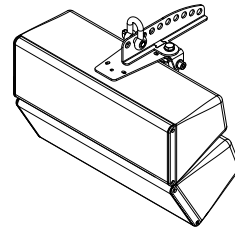

E6507 Assembly

2.6 Z5423 Fixing template

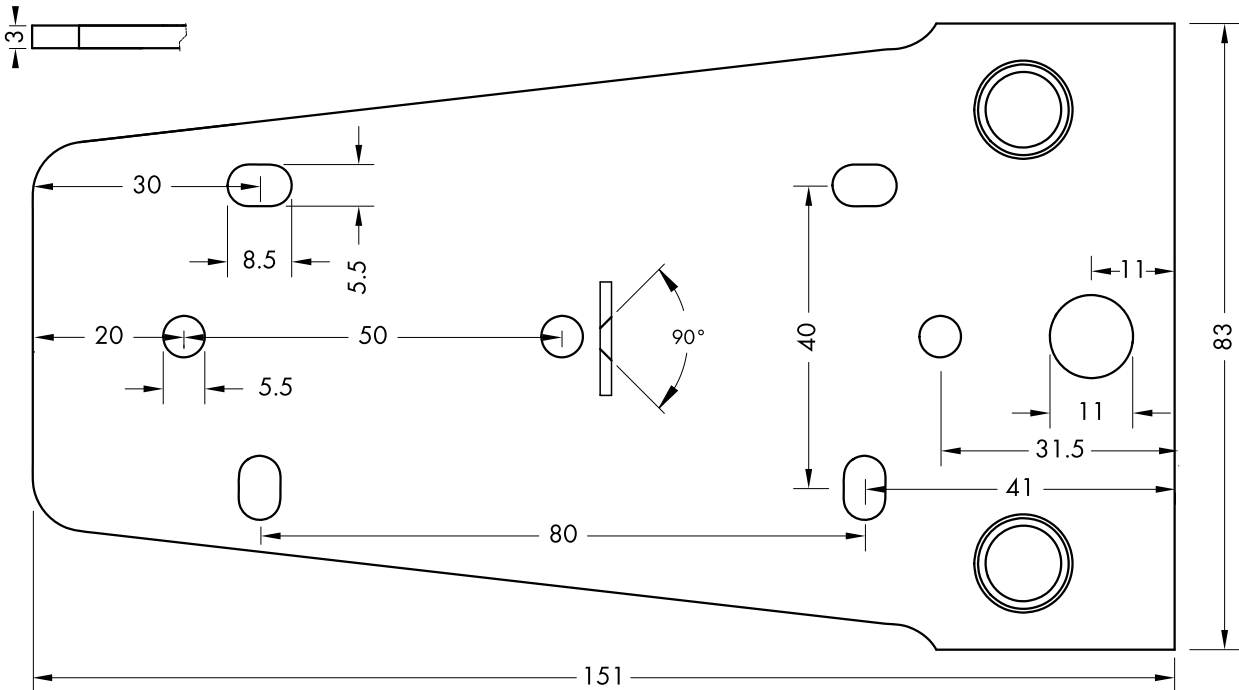

Note: Scale 100% (1:1)

3 Z5424 44S L-mount adapter

3.1 Scope of supply and weight

Please verify the shipment for completeness and proper condition of the items.

Qty.	d&b Code	Description
1	Z5424	44S L-mount adapter [1]
Including:		
2		U washer 8.4 [2]
2		Fixing screw M8 x 20 mm/ Torx #T45 [3]
4		Stick-on rubber pad [4]
1	D2634.EN .01	44S Accessories Mounting instructions

Weight (incl. all items) 1 kg (2.2 lb)

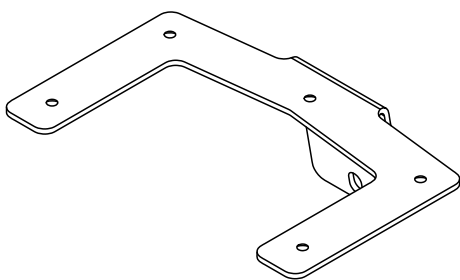
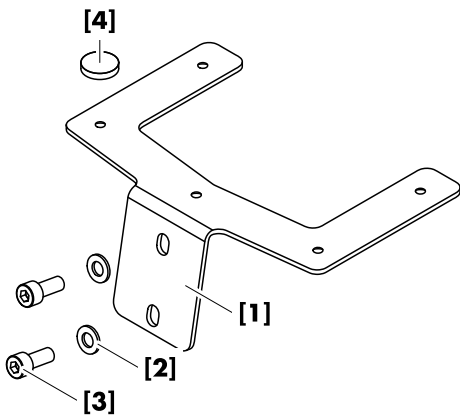

3.2 Mounting options and angle settings

The Z5424 L-mount adapter serves to attach a single 44S cabinet directly to ceilings or floors (e.g. stage lips). It can be also attached to walls or any other suitable surface.

The enclosed stick-on rubber pads **[4]** are intended for temporary (mobile) floor applications to prevent the surface from scratching.

Depending on the orientation of the cabinet, the adapter allows for fixed tilt angles of 0° or ± 20°.

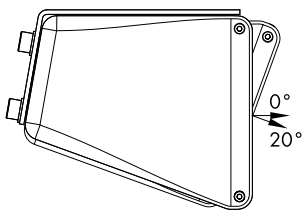

Option 1: Ceiling

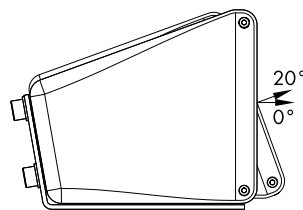

Option 2: Floor

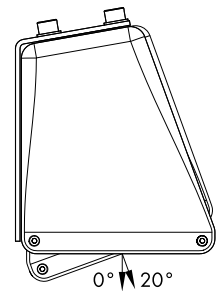

Option 3: Wall

3.3 Assembly

Attaching the bracket to ceilings or walls

NOTICE!

Only use mounting parts (fixing anchors and screws) that are suitable for the intended application.

To attach the adapter to ceilings, floors or walls, use the holes shown in the graphic opposite to provide adequate support. A corresponding fixing template is provided in these mounting instructions (please refer to ⇒ Chapter 3.4 "Z5424 Fixing template" on page 10).

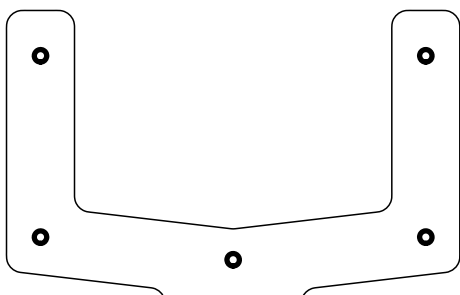

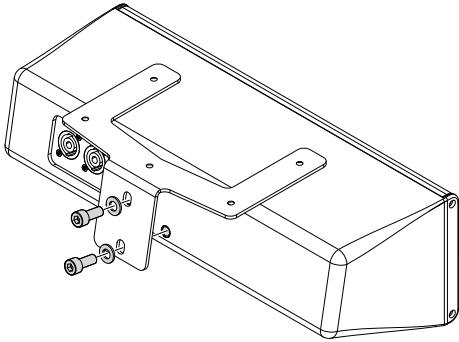

Attaching the cabinet to the adapter

NOTICE!

Only use the supplied and specified screws **[3]**, otherwise there is a risk of damaging the threaded inserts.

Always use the U washers **[2]** to prevent the bolts from slackening.

Tools required:

- Torque wrench (torx size #T45)

1. Once the adapter is fixed in its operating position, attach the cabinet to the adapter.
2. Insert the screws **[3]** together with the U washers **[2]**.
3. Tighten the screws with a maximum torque of 4 N·m.

3.4 Z5424 Fixing template

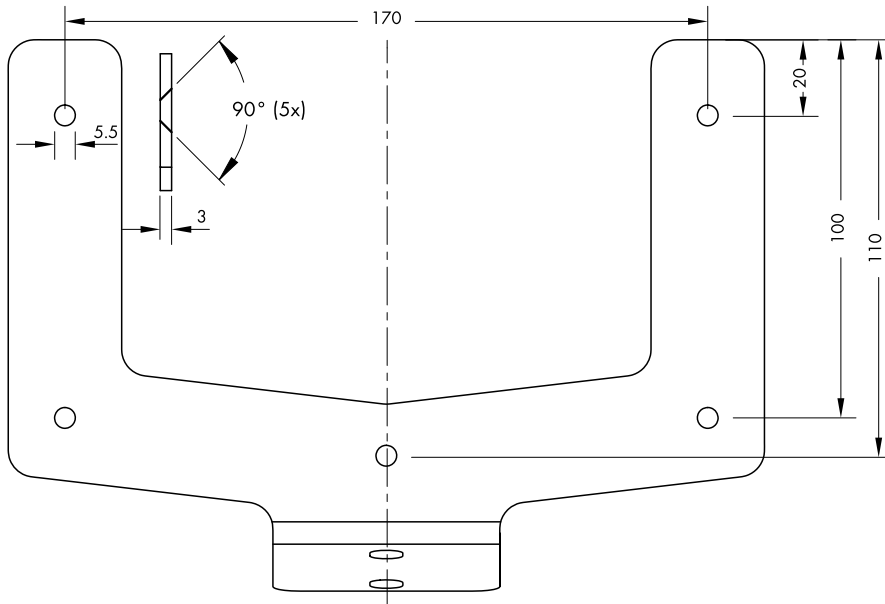

Note: Scale 50% (1:2)

4 Z5426 44S Swivel bracket

4.1 Scope of supply and weight

Please verify the shipment for completeness and proper condition of the items.

Qty.	d&b Code	Description
1	Z5426	44S Swivel bracket [1]
Including:		
2		U washer 8.4 [2]
1		Fixing screw M8 x 20 mm/ Torx #T45 [3]
1	Q9031	Safety eye bolt M8 [4] (intended for the attachment of a secondary safety device)
1	D2634.EN .01	44S Accessories Mounting instructions

Weight (incl. all items) 1.5 kg (3.3 lb)

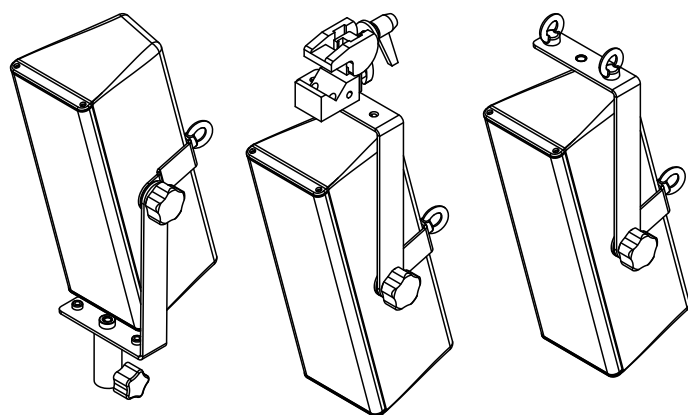
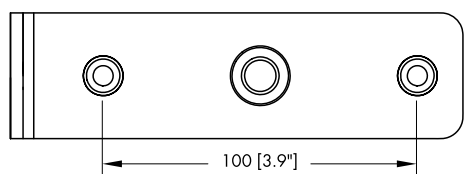
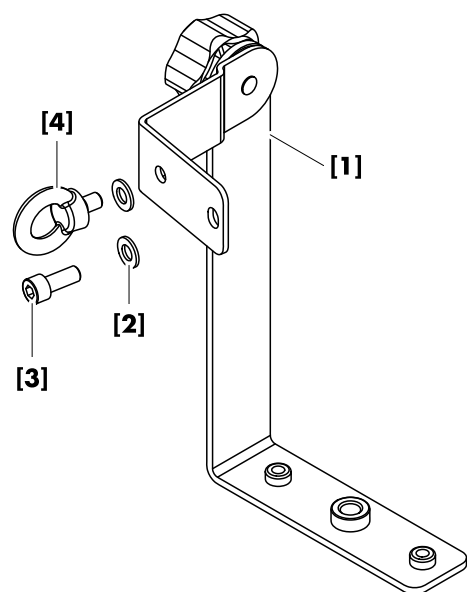

Z5426 44S Swivel bracket with:

- Z5034 Stand adapter M10
- E6532 Super clamp together with the d&b E6533 Adapter M10
- Q9031 Safety eyebolt

4.2 Mounting options and angle settings

The tie bar of the bracket provides a center M10 threaded insert and two threaded inserts M8 at a distance of 100 mm (3.9") to accept the following accessories:

The bracket can be...

- mounted on loudspeaker stands with a tube diameter of 35 mm (1.4") using the d&b Z5034 Stand adapter M10.
- vertically flown from overhead bars or truss with a tube diameter of up to 55 mm (2.1") using the d&b E6532 Super clamp together with the d&b E6533 Adapter M10. Alternatively the d&b Z5029 TV spigot M10 together with the d&b Z5012 Pipe clamp can be used for a tube diameter of up to 70 mm (2.75).
- vertically flown using appropriate steel wires together with two d&b Q9031 Safety eyebolts M8, attached to the outer M8 threaded inserts of the tie bar.

Note: For assembly and operation of these accessories, refer to the specific mounting instructions.

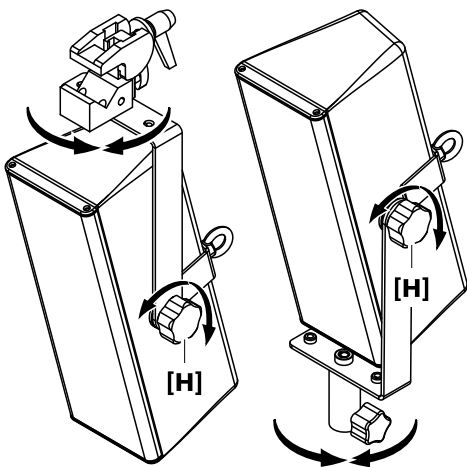
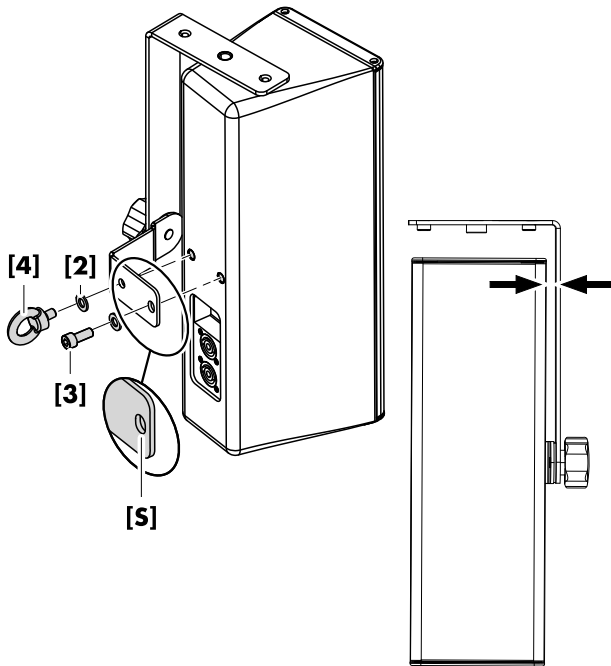

4.3 Assembly

NOTICE!

Only use the supplied and specified screws [3]/[4], otherwise there is a risk of damaging the threaded inserts.

Always use the U washers [2] to prevent the bolts from slackening.

Tools required:

- Torque wrench (torx size #T45)

Observe the correct orientation of the cabinet, as shown in the graphic opposite.

1. Attach the bracket to the cabinet from the rear.
2. Insert the safety eyebolt [4] and screw [3] together with the U washers [2].
 - ↳ The fixing plate of the bracket provides one slotted hole [S] to allow the precise alignment of the cabinet parallel to the bracket's side leg.
3. First slightly tighten the safety eyebolt [4].
4. Align the cabinet until its side panel is parallel to the side leg of the bracket and tighten the screws with a maximum torque of 4 N·m.

Alignment

Vertical alignment:

1. Slacken the handbolt [H].
2. Set your desired vertical angle and retighten the handbolt.

Horizontal alignment:

The horizontal alignment is carried out using the particular rigging component (e.g. truss clamp or stand adapter).



5.1 Conformity of rigging components

This declaration applies to:

- d&b Z5423 44S Mounting bracket
- d&b Z5424 44S L-mount adapter
- d&b Z5425 44S Cluster bracket
- d&b Z5426 44S Swivel bracket

by d&b audiotechnik GmbH & Co. KG.

All product variants are included, provided they correspond to the original technical version and have not been subject to any later design or electromechanical modifications.

We herewith declare that said products are in conformity with the provisions of the respective directives including all applicable amendments.

Detailed and applicable declarations are available on request and can be ordered from d&b or downloaded from the d&b website at www.dbaudio.com.

5.2 Disposal

When out of use the rigging components must be disposed of in accordance with the national environmental regulations.

Ensure that damaged rigging components are disposed of in a way that they cannot be used again.

WEEE-Reg.-Nr. DE: 13421928

