

xD

25D
Start-up manual
1.1 en

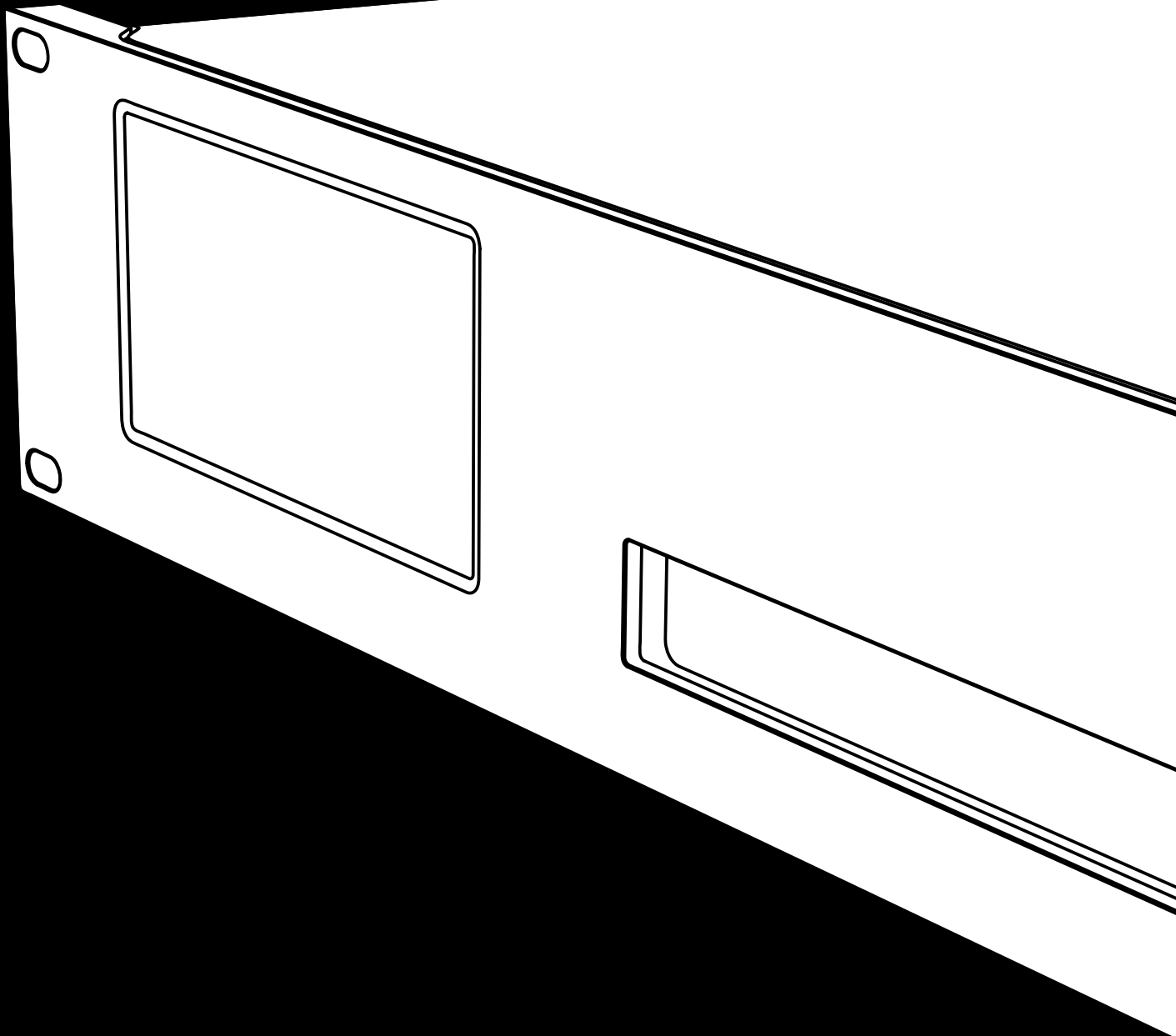

Notes on document version

Version 1.1:

Initial edition.

General information

25D Start-up manual

Version: 1.1 en, 07/2025, D2061.EN .01

Copyright © 2025 by d&b audiotechnik GmbH & Co. KG; all rights reserved.

Keep this document with the product or in a safe place so that it is available for future reference.

We recommend you to regularly check the d&b website for the latest version of this document.

When reselling this product, hand over this document to the new owner.

If you supply d&b products, please draw the attention of your customers to this document. Enclose the relevant documents with the systems. If you require additional documents for this purpose, you can order them from d&b.

d&b audiotechnik GmbH & Co. KG
Eugen-Adolff-Str. 134, D-71522 Backnang, Germany
T +49-7191-9669-0, F +49-7191-95 00 00
docadmin@dbaudio.com, www.dbaudio.com

Explanation of graphical symbols



The lightning symbol within a triangle is intended to alert the user to the presence of uninsulated "dangerous voltages" within the unit's chassis that may be of sufficient magnitude to constitute a risk of electric shock to humans.



The exclamation point within a triangle is intended to alert the user to the presence of important operating and service instructions in the literature accompanying the product.

Before using this product, carefully read the applicable items of the following safety instructions.

1. Keep these instructions for future reference.
2. Read these instructions.
3. Heed all warnings.
4. Follow all instructions.
5. **WARNING!** To reduce the risk of fire or electric shock:
 - Do not expose this unit to rain or moisture.
 - Keep water or other liquids away from the unit.
 - Do not place liquid filled containers, for example beverages, on top of the unit.
 - Do not operate the unit while it is wet or standing in liquid.
6. Always operate the unit with the chassis ground wire connected to the electrical safety earth.
Do not defeat the safety purpose of a grounding-type plug. A grounding-type plug has two blades and a third grounding prong. The third prong is provided for your safety. If the provided plug does not fit into your outlet, consult an electrician for replacement of the obsolete outlet.
7. Do not use this unit if the power cord is damaged or frayed. Protect the power cord from being walked upon or pinched, particularly at the plugs and the point where it exits from the apparatus.
8. The unit is intended for use in a 19" rack. Follow the mounting instructions. When a rack on wheels is used, exercise caution when moving the loaded rack to avoid injury from tipping over.
9. Unplug this apparatus during lightning storms or when unused for long periods of time.
10. Never connect an output pin to any other amplifier input or output pin or to the earth (ground). This may damage the unit or lead to electric shock.
11. Lay all cables connected to the unit carefully so that they cannot be crushed by vehicles or other equipment and that no one can either step on them or trip over them.
12. Refer all servicing to qualified service personnel. Servicing is required when the apparatus has been damaged in any way such as:
 - Power-supply cord or plug is damaged.
 - Liquid has been spilled into the unit.
 - An object has fallen into the unit.
 - The unit has been exposed to rain or moisture.
 - The unit does not operate normally.
 - The unit was dropped or the chassis is damaged.
 - Do not remove top or bottom covers. Removal of the covers will expose hazardous voltages. There are no user serviceable parts inside and removal may void the warranty.
13. Use the mains plug as the disconnecting device and keep it readily accessible. If the mains plug is not readily accessible due to mounting in a 19" equipment cabinet, then the mains plug for the entire rack must be readily accessible.
14. An experienced user must always supervise the equipment, especially if inexperienced adults or minors are using the equipment.

WARNINGS!



To prevent electric shock do not remove top or bottom covers. No user serviceable parts inside, refer servicing to qualified service personnel.

Français : À prévenir le choc électrique n'enlevez pas les couvercles. Il n'y a pas des parties serviceable à l'intérieur, tous reparations doit être faire par personnel qualifié seulement.



To completely disconnect this equipment from the AC mains, disconnect the power supply cord plug from the AC receptacle. The mains plug of the power supply cord shall remain readily operable.

Français : Pour démonter complètement l'équipement de l'alimentation générale, démonter le câble d'alimentation de son réceptacle. La prise d'alimentation restera aisément fonctionnelle.



To reduce risk of fire or electric shock, do not expose this apparatus to rain or moisture.

Français : Pour réduire les risques d'incendie ou de choc électrique, n'exposez pas l'appareil à la pluie ou à l'humidité.



Do not expose this system/apparatus to dripping or splashing and ensure that no objects filled with liquids, such as vases, are placed on the apparatus.

Français : N'exposez pas ce système/appareil au ruissellement ni aux éclaboussures et assurez-vous qu'aucun objet contenant du liquide tel qu'un vase n'est placé sur l'appareil.



This apparatus must be connected to a mains socket outlet with a protective earthing connection.

Français : Cet appareil doit être raccordé à une prise secteur avec terre de protection.



The mains plug is used as a disconnect device and shall remain readily operable.

Français : Lorsque la prise du réseau d'alimentation est utilisés comme dispositif de déconnexion, ce dispositif doit demeurer aisément accessible.

CAUTION!



To reduce the risk of fire or electric shock, do not remove screws. No user-serviceable parts inside. Refer servicing to qualified service personnel.

Français : Pour réduire le risque d'incendie ou de choc électrique, ne pas retirer les vis. Aucune pièce réparable par l'utilisateur. Confier l'entretien à personnel qualifié.

- 1 Intended use..... 6**
- 1.1 About this manual..... 6
- 1.2 Loudspeaker types..... 6
- 2 Scope of supply..... 7**
- 3 Technical specifications..... 8**
- 3.1 Current/power draw and thermal dissipation..... 11
- 4 Overview..... 13**
- 4.1 Connections..... 13
- 4.2 Controls and indicators - User interface..... 13
- 5 Startup..... 14**
- 5.1 Rack mounting and cooling..... 14
- 5.2 Connections..... 15
- 5.2.1 Mains connection..... 15
- 5.2.2 Audio INPUT and LINK/OUT connectors..... 16
- 5.2.3 SPEAKER OUTPUTS..... 17
- 5.2.4 ETHERNET (Dual Ethernet port)..... 18
- 5.2.5 GPI/GPO (Hardware description)..... 19
- 5.2.6 FAULT..... 19
- 5.3 Controls and indicators..... 20
- 5.3.1 RESET (System reset)..... 20
- 5.3.1.1 Network reset option (IP settings)..... 20
- 5.3.2 TFT color touchscreen - User interface..... 21
- 6 Device configuration..... 22**
- 6.1 Initial device setup..... 22
- 7 Service/Maintenance and care..... 23**
- 7.1 Service..... 23
- 7.2 Maintenance and care..... 23
- 7.2.1 Touchscreen cleaning..... 23
- 8 Manufacturer's declarations..... 24**
- 8.1 Declaration of Conformity..... 24
- 8.2 WEEE Declaration (Disposal)..... 24
- 8.3 Licenses and Copyright..... 24

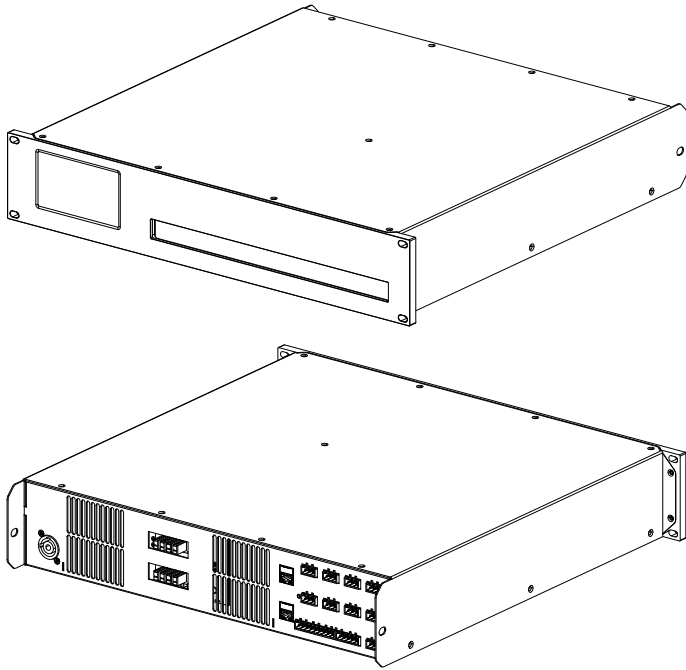

The d&b 25D amplifier is designed for installation purposes and is intended to be used with applicable d&b loudspeakers.

A "LINEAR" setup is available allowing the amplifier to be used as a linear power amplifier.

Note: d&b audiotechnik will accept no liability for any damages to third-party loudspeakers when operated with d&b amplifiers in "LINEAR" mode.

NOTICE!

The device complies with the electromagnetic compatibility requirements of EN 55032:2019 (product family standard for audio, video, audio-visual and entertainment lighting control apparatus for professional use) for the environment Class B (residential).

Acoustic interferences and malfunctions may occur if the unit is operated in the immediate vicinity of high-frequency transmitters (e.g. wireless microphones, mobile phones, etc.). Damage to the device is unlikely, but cannot be excluded.

1.1 About this manual

With respect to the vast functionality and high complexity of the device, this manual covers the basic safety instructions as well as the vital technical specifications and instructions for startup.

A full version of this manual in English language (⇒ Reference manual) with comprehensive information is available for download on the related product page of the d&b website at www.dbaudio.com.

1.2 Loudspeaker types

The maximum number of cabinets driven by each channel varies depending on their nominal impedance. It can be found in the respective loudspeaker manual and also in the data section of each loudspeaker product page on the d&b website at www.dbaudio.com.

The minimum recommended impedance per channel is 4 ohms.

Nom. impedance	Cabinets per channel
4 Ω	1
8 Ω	2
12 Ω	3
16 Ω	4
20 Ω	5

A list of d&b loudspeakers supported by the amplifier is included in the Release notes of the amplifier firmware. The latest version can be found on the related product page of the d&b website at www.dbaudio.com.

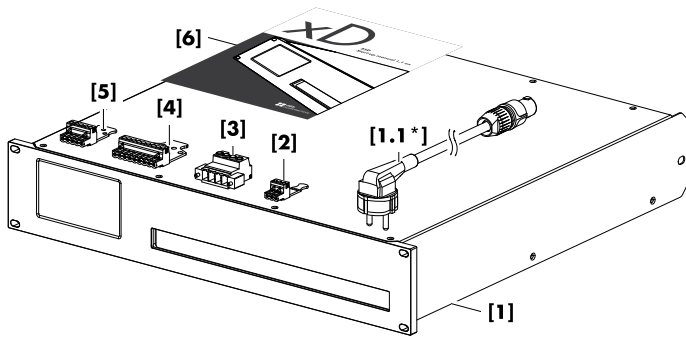

Before starting up the device, please verify the shipment for completeness and proper condition of the items.

If there is any sign of obvious damage to the unit and/or the power cord, do not operate the unit and contact your local dealer from whom you received it.

Pos.	Qty.	d&b Code	Description
[1]	1	Z2810	d&b 25D Amplifier
Including:			
[1.1*]	1	Z2612.xxx	Power cord (specific to country*)
[2]	9		3-pin Phoenix Euroblock female: <ul style="list-style-type: none"> Intended for the INPUT/LINK/FAULT connector sockets. Connector type: MSTB 2.5 / 3-STZ - Phoenix order code: 1776168
[3]	2		4-pin Phoenix Euroblock male: <ul style="list-style-type: none"> Intended for the SPEAKER OUTPUTS connector sockets. Connector type: IPC 5/4-STF-7.62 - Phoenix order code: 1709173
[4]	1		9-pin Phoenix Euroblock female: <ul style="list-style-type: none"> Intended for the GPI connector socket. Connector type: MSTB 2.59-STZ-5.08 - Phoenix order code: 1764316
[5]	1		5-pin Phoenix Euroblock female: <ul style="list-style-type: none"> Intended for the GPO connector socket. Connector type: MSTB 2.55-STZ-5.08 - Phoenix order code: 1776142
[6]	1	D2061.EN .01	d&b 25D Start-up manual.

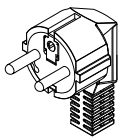

Z2612.000
3-pin Schuko
CEE 7/7

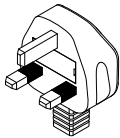

Z2612.010
3-pin UK
BS 1363A

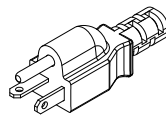

Z2612.024*
3-pin U.S.
NEMA 5-20P
*within delivery

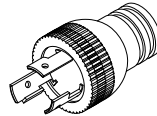

Z2612.025*
3-pin U.S.
NEMA L6-20P
*optional

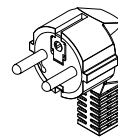

Z2612.040
3-pin South Korea
KS C8305

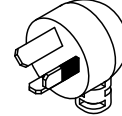

Z2612.050
3-pin Australia
AS 3112

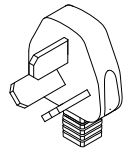

Z2612.060
3-pin China
GB 2099

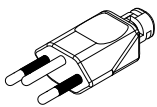

Z2612.070
3-pin Switzerland
SEV 1011

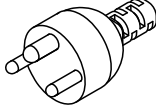

Z2612.090
3-pin Denmark
Afsnit 107-2-D1

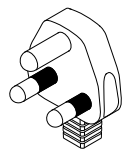

Z2612.100
3-pin South Africa
SANS 164-1

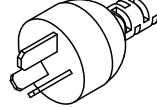

Z2612.110
3-pin Argentina
IRAM 2073

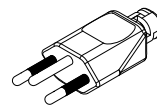

Z2612.120
3-pin Brazil
NBR 14136

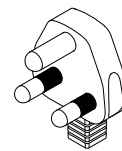

Z2612.130
3-pin India
IS 1293

*** Mains plug types and associated standards**
(Similar illustrations, not in scale)

Operating conditions

Operating temperature (*continuous/**short-term)	-10 °C ... +40*/+50** °C (+14 °F ... +104*/+122** °F)
Storage temperature	-20 °C ... +70 °C (-4 °F ... +158 °F)
Humidity (rel.), non-condensating	< 70 %
Maximum height above sea level	2000 m/6560 ft

Power supply

Switched mode power supply with automatic mains range selection and active Power Factor Correction (PFC).

Mains connector	powerCON® TRUE 1 TOP
Mains fuse	internal
Rated mains voltage (High range)	208 - 240 V, 50 - 60 Hz
Rated mains current (High range)	13 A
Rated mains voltage (Low range)	100 - 127 V, 50 - 60 Hz
Rated mains current (Low range)	20 A

Protection circuits

Mains and power supply: Overvoltage and undervoltage, inrush current limiter, internal fuse.

Output: Overcurrent, DC offset, HF voltage limiter, pop-noise suppression.

Cooling: Temperature-dependent RPM of fan, self-resetting overtemperature protection.

Power consumption (typical values)

Standby	21 W
Idling	130 W
Peak output	2275 W

Audio power outputs *

SPEAKER OUTPUTS A/B/C/D	2 x 4-pin Phoenix Euroblock female
Maximum output voltage/current	120 V _{peak} /35 A _{peak}
Output power rating EIA-426B noise CF 12 dB	4 x 900 W/8 Ω
	4 x 1800 W/4 Ω
Sine wave 1 kHz, long term, +40 °C (+104 °F)	4 x 250 W/4 Ω
Frequency response (-1 dB, Linear mode)	35 Hz - 25 kHz
Gain (Linear mode @ 0 dB)	31 dB

Output noise/Dynamic range

Output noise (BW 20 kHz)/dynamic range (BW 20 kHz, reference 180 V _{pk})	
Analog input	350 μV _{RMS} /108 dB
Analog input, A-weighting	280 μV _{RMS} /110 dB
Digital/Milan input	220 μV _{RMS} /112 dB
Digital/Milan input, A-weighting	170 μV _{RMS} /114 dB

THD+N/Crosstalk

THD+N (unweighted, 20 - 20 kHz)	
4 x 250 W/8 ohms	< -86 dB/0.005 %
4 x 250 W/4 ohms	< -83 dB/0.007 %
Crosstalk (20 - 20 kHz)	< -70 dB
	4 x 250 W into 8/4 Ω

Analog inputs and outputs

INPUT A1 - A4	3-pin Phoenix Euroblock male
Pin assignment	(↓) GND, neg., pos.
Input impedance	32 kΩ, electronically balanced
CMRR @ 100 Hz/1 kHz / 10 kHz	>80/>80/>70 dB
Maximum input level (balanced/unbalanced)	+25/+18 dBu
	+27.3 dBu @ 0 dBFS

Digital inputs and outputs

INPUT - D1/2, D3/4	3-pin Phoenix Euroblock male, AES3
Pin assignment	(↓) GND, AES Signal, AES Signal
Input impedance	110 Ω, transformer balanced
Sampling frequency	44.1 48 96 192 kHz
Word length	16 - 24 bit
LINK - D1/2, D3/4	3-pin Phoenix Euroblock male
Pin assignment	(↓) GND, AES Signal, AES Signal
	electronically balanced
Output modes	Mains on: analog signal buffering (refresh)
	Mains off/power fail: bypass relay

Milan™ inputs

Device type	Endstation
Input channel streams	1 stream with up to 8 channels @ 48/96 kHz
Redundancy	Yes (always)
Routable Milan™ inputs	M1-8

Digital Signal Processing

System start-up time	< 45 sec.
Time to tone (Standby/ReadyStandby)	< 4/< 1 sec.
Time to tone (Off/Wake on Audio)	< 45 /< 4 sec.
Conversion	96 kHz
Latency analog/digital (AES) input	0.3/0.3 msec.
A/D conversion	27 Bit (dual-stacked A/D converters)
Internal processing	Combination of high-resolution fixed point and floating point processing
Equalizer	two user definable 16-band equalizers
	Filter types: PEQ/Notch/HiShlv/LoShlv/Asym
Delay	0.3 msec. - 10 sec.
Frequency generator	Pink noise or Sine wave 10 Hz - 20 kHz

Network connections

Connector type	2 x RJ 45
Switch	integrated 2-port, 1 Gbit/100 Mbit
IP address/Subnet mask	192.168.1.25/255.255.255.0
ETHERNET 1/PRI	Milan™, Remote control via R1 star topology
ETHERNET 2/SEC	Milan™ redundancy only, no remote control star topology

IP settings (factory default)

IP address/Subnet mask	192.168.1.25/255.255.255.0
------------------------	----------------------------

GPI/GPO/FAULT

External power supply 24 VDC \pm 25% (18 - 30 VDC)/150 W

GPI 8 x Opto-coupled (galvanic isolation)
 High-level 18 ... 30 VDC
 Low-level 0 ... 9 VDC
 Serial resistance 5.4 kOhms
 Forward voltage drop ($U_{f(max.)}$) 3.7 V
 Input current draw per pin @ 9/18/24/30 VDC
 1.5/2.6/3.7/4.8 mA
 Connector type 1 x 9-pin Phoenix Euroblock male
 Pin assignment (\downarrow) GND, GPIs 1 - 8

GPO 4 x Low-Side-Switch-Relay
 High-state Closed (connected to common GPO GND)
 Low-state Open (high resistive)
 Max. current draw 1 A/Total: 4 A
 Connector type 1 x 5-pin Phoenix Euroblock male
 Pin assignment (\downarrow) GND, GPOs 1 - 4

FAULT NO - Normally Open | NC - Normally Closed
 1 x 3-pin Phoenix Euroblock male

Controls and indicators

RESET Recessed push-button (rear panel)
 TFT color touchscreen 4.3"/480 x 272 pixels

Fan noise emission

Rack mounted, measured on axis, 1 m (3.3 ft) to front panel, A-weighting.
 Min./Max. RPM 30/50 dB(A)
 Ambient temperature 23 °C/73.4 °F

Dimensions and weight

Height x width x depth 2 RU x 19" x 465 mm (18.3")
 Weight 13.3 kg/29.3 lb

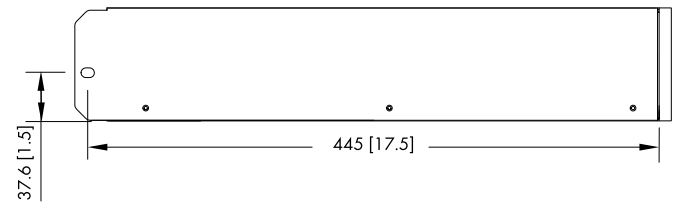
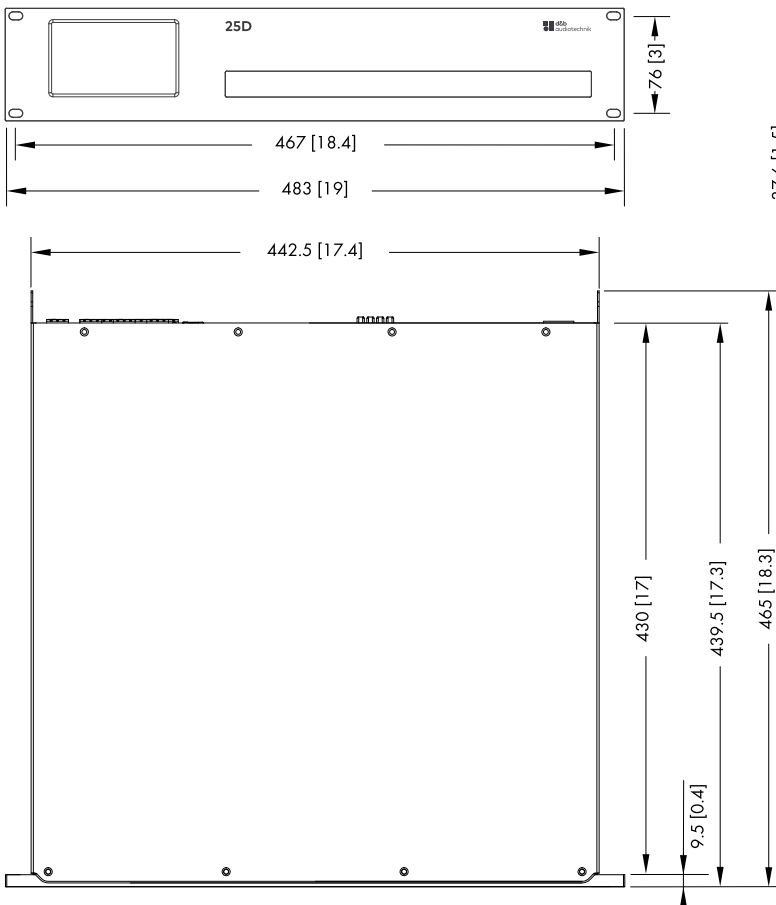

25D enclosure dimensions in mm [inch]

*** Audio power output – Measurement references:**

All data is valid for 23 °C (73.4 °F) ambient temperature and 230 VAC/50 Hz mains supply.

The power rating of noise signals is defined as the maximum of the instantaneous output power divided by a factor of two.

The power of burst signals refers to the power during the "on" period.

The duration of the peak output of a sine wave signal is defined at a drop of 0.5 dB/10% relative to the maximum output power.

EIA-426B noise			
Crest factor	Load [ohms]	Power rating [W]	Power average [W]
12 dB	8	4 x 900	4 x 112.5
	4	4 x 1800	4 x 225
9 dB	8	4 x 900	4 x 225
	4	4 x 1300	4 x 325
6 dB	8	4 x 900	4 x 450
	4	4 x 700	4 x 350
1 kHz burst			
On/off time	Load [ohms]	Power [W]	
20 ms/0 dB 480 ms/-20 dB	8	4 x 800	
	4	4 x 1050	
200 ms/0 dB 600 ms/-20 dB	8	4 x 750	
	4	4 x 700	
1 kHz sine wave			
Channels used	Load [ohms]	Max. output power [W]	Duration of max. output
1	8	1 x 900	> 10 s
	4	1 x 1800	230 ms
4	8	4 x 900	11 ms
	4	4 x 1800	4 ms

3.1 Current/power draw and thermal dissipation

Measurement references

For all noise signals, the values are measured at the maximum level just before any amplifier limiter activity (no Gain Reduction).

Noise CF 12 dB: Noise signal according to EIA-426-B with a crest factor of 12 dB.

This represents the use case of live music or less compressed recorded music.

Noise CF 9 dB: Noise signal according to EIA-426-B with a crest factor of 9 dB.

This represents the use case of music with medium compression.

Noise CF 6 dB: Noise signal according to EIA-426-B with a crest factor of 6 dB.

This represents the use case of heavily compressed music.

Sine wave (100 ms): 1 kHz sine wave signal, 0 dBFS input level and a duration of 1 s.

The RMS current value is calculated over a 100 ms time window. This window is stepped in increments of 10 ms over the recording. The resulting value is the highest current within a window of 100 ms.

230 V AC / 50 Hz / 0.5 Ω Source impedance - all channels driven								
State	Load [ohms]	Mains current [A RMS]	Power factor	Input power [W]	Output power [W]	Power loss [W]	BTU/hr	kCal/hr
Off	-	0.24	0.03	1.5	-	1.5	5	1
Standby	-	0.29	0.31	20.8	-	20.8	71	18
ReadyStandby	-	0.43	0.54	52.6	-	52.6	179	45
Eco	-	0.83	0.54	103	-	103	351	89
Idling	-	0.75	0.74	127	-	127	433	109
Noise CF 12 dB	8	3.1	0.94	675	450	225	768	194
	4	5.7	0.96	1275	900	375	1279	323
Noise CF 9 dB	8	5.5	0.97	1200	900	300	1024	258
	4	8.1	0.98	1800	1300	500	1706	430
Noise CF 6 dB	8	9.9	0.98	2250	1800	450	1535	387
	4	8.6	0.98	1950	1400	550	1876	473
Sine wave max. 1 s	8	17.4	-	-	-	-	-	-
	4	17.3	-	-	-	-	-	-

208 V AC / 60 Hz / 0.5 Ω Source impedance - all channels driven								
State	Load [ohms]	Mains current [A RMS]	Power factor	Input power [W]	Output power [W]	Power loss [W]	BTU/hr	kCal/hr
Off	-	0.26	0.02	1.3	-	1.3	4	1
Standby	-	0.32	0.32	20.8	-	20.8	71	18
ReadyStandby	-	0.46	0.53	50.2	-	50.2	171	43
Eco	-	0.86	0.84	97	-	97	331	83
Idling	-	0.82	0.74	126	-	126	430	108
Noise CF 12 dB	8	3.5	0.94	675	450	225	768	194
	4	6.4	0.96	1300	900	400	1365	344
Noise CF 9 dB	8	6.1	0.97	1250	900	350	1194	301
	4	9.1	0.98	1850	1300	550	1876	473
Noise CF 6 dB	8	11.0	0.99	2275	1800	475	1621	409
	4	9.6	0.98	1975	1400	575	1962	495
Sine wave max. 1 s	8	19.3	-	-	-	-	-	-
	4	19.3	-	-	-	-	-	-

120 V AC / 60 Hz / 0.2 Ω Source impedance - all channels driven								
State	Load [ohms]	Mains current [A RMS]	Power factor	Input power [W]	Output power [W]	Power loss [W]	BTU/hr	kCal/hr
Off	-	0.15	0.02	0.4	-	0.4	1	0.5
Standby	-	0.32	0.50	18.8	-	18.8	64	16
ReadyStandby	-	0.60	0.72	52.0	-	52.0	177	45
Eco	-	1.44	0.60	104	-	104	355	59
Idling	-	1.26	0.86	130	-	130	444	112
Noise CF 12 dB	8 4	6.0 11.3	0.96 0.97	700 1300	450 900	250 400	853 1365	215 344
Noise CF 9 dB	8 4	10.7 16.0	0.97 0.98	1250 1875	900 1300	350 575	1194 1962	301 495
Noise CF 6 dB	8 4	19.1 17.0	0.99 0.98	2250 2000	1700 1400	550 600	1876 2047	473 516
Sine wave max. 1 s	8 4	22.7 24.4	- -	- -	- -	- -	- -	- -

100 V AC / 60 Hz / 0.2 Ω Source impedance - all channels driven								
State	Load [ohms]	Mains current [A RMS]	Power factor	Input power [W]	Output power [W]	Power loss [W]	BTU/hr	kCal/hr
Off	-	0.13	0.02	0.3	-	0.3	1	0.5
Standby	-	0.34	0.55	18.7	-	18.7	64	16
ReadyStandby	-	0.65	0.75	48.2	-	48.2	164	41
Eco	-	1.54	0.61	94.8	-	94.8	323	82
Idling	-	1.45	0.88	128	-	128	437	110
Noise CF 12 dB	8 4	7.3 13.8	0.96 0.97	700 1350	450 900	250 450	853 1535	215 387
Noise CF 9 dB	8 4	13.0 19.7	0.98 0.99	1275 1925	900 1300	375 625	1279 2132	323 538
Noise CF 6 dB	8 4	20.3 19.9	0.99 0.99	2000 1950	1450 1300	550 650	1876 2218	473 559
Sine wave max. 1 s	8 4	26.8 28.9	- -	- -	- -	- -	- -	- -

4.1 Connections

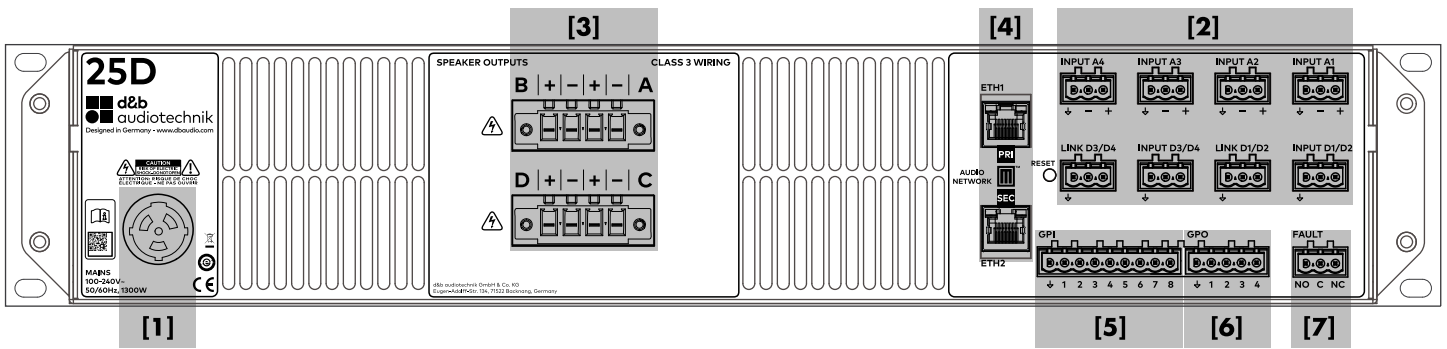

[1] Mains connector socket.
Refer to ⇒ Chapter 5.2.1 "Mains connection" on page 15.

[3] Output connectors.
Refer to ⇒ Chapter 5.2.3 "SPEAKER OUTPUTS" on page 17.

[2] Audio INPUT (analog/digital) and LINK connectors.
Refer to ⇒ Chapter 5.2.2 "Audio INPUT and LINK/OUT connectors" on page 16.

[4] ETHERNET.
Refer to ⇒ Chapter 5.2.4 "ETHERNET (Dual Ethernet port)" on page 18.

[5] GPI connector.
[6] GPO connector.
Refer to ⇒ Chapter 5.2.5 "GPI/GPO (Hardware description)" on page 19.

[7] FAULT connector.
Refer to ⇒ Chapter 5.2.6 "FAULT" on page 19.

4.2 Controls and indicators - User interface

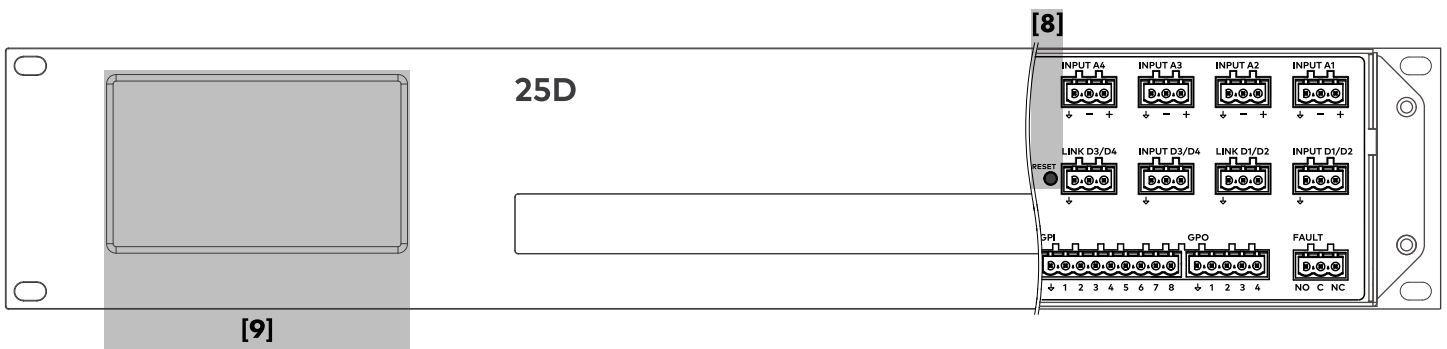

[9] User interface / Status indicators
Refer to ⇒ Chapter 5.3.2 "TFT color touchscreen - User interface" on page 21.

[8] RESET
Refer to ⇒ Chapter 5.3.1 "RESET (System reset)" on page 20.

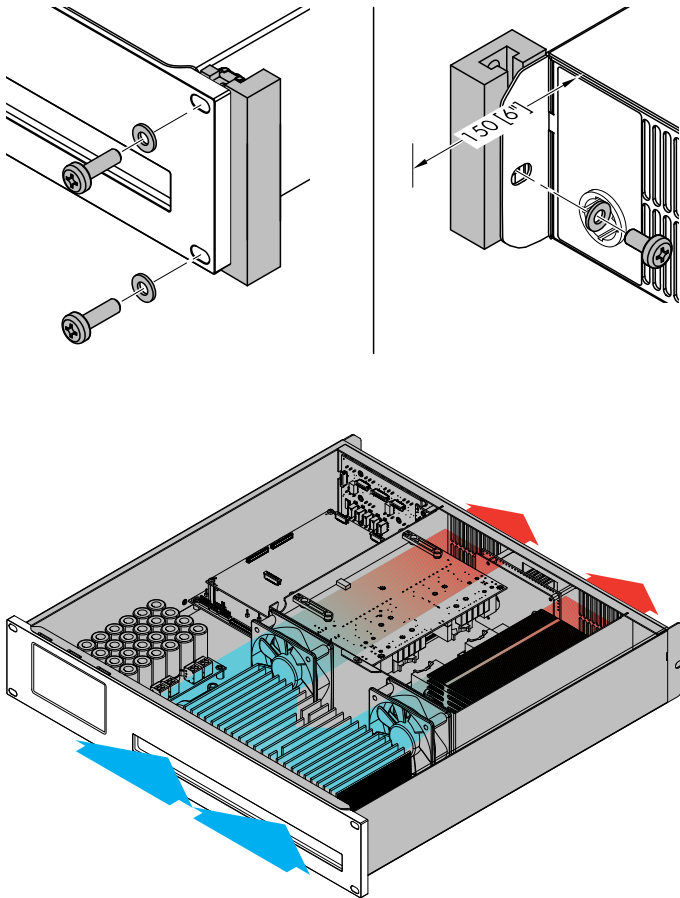

5.1 Rack mounting and cooling

Rack mounting

The enclosure is designed to fit standard 19" equipment racks or cabinets.

NOTICE!

When mounting the device into 19" equipment racks or cabinets, it is strongly recommended that you:

- **Always** fix the device at its **front AND rear rack ears** using appropriate rack mounting screws and U-washers, as shown in the graphic opposite.
 - Alternatively use shelves fixed to the inner sides of the equipment rack or cabinet.
-

Cooling

Thermal conditions are a vital factor to ensure operational safety of the power amplifiers. The amplifiers are equipped with two internal fans that draw cool air from the front into the housing and channel the warm air towards the back of the device.

- Please ensure that adequate cool airflow is provided.
- Do not block or cover the front panel air intake or the vents on the rear panel.
- If the amplifiers are installed in sealed cabinets (e.g. in fixed installations), use additional fan modules with filters that can be easily replaced without opening the sealed cabinets.
- Do not combine the amplifiers with D6 or D12 amplifiers in one rack.
- Do not rack up the amplifiers together with other devices producing additional heat with opposing airflow.

5.2 Connections

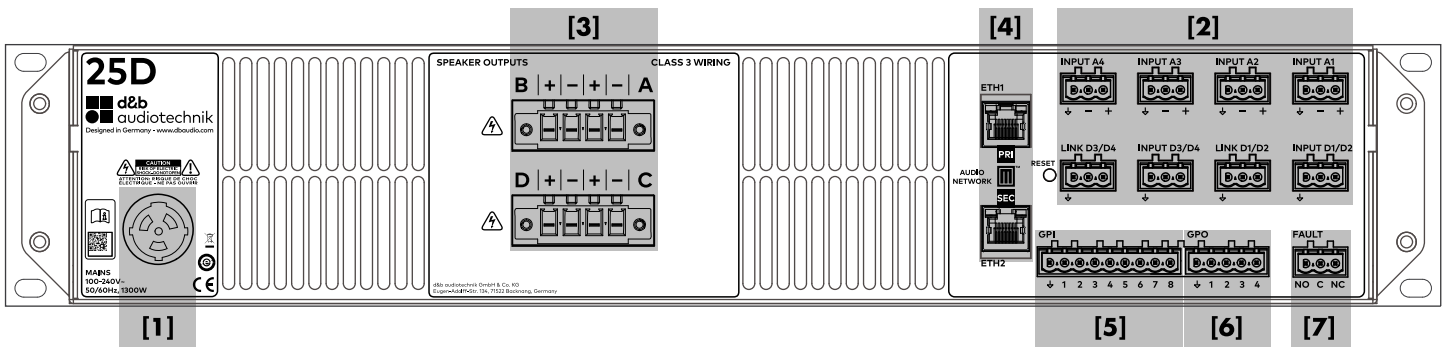

5.2.1 Mains connection

WARNING!
Potential risk of electric shock or fire.

The device is a protective class 1 unit. A missing earth (ground) contact may cause dangerous voltages in the housing and controls and may lead to electric shock.

- Connect the device to mains power supplies with protective earth only.
- If there is any sign of obvious damage to the power cord and/or mains plug, do not use the power cord and replace it before further use.
- Please ensure the mains connector is accessible at any time to disconnect the device in case of malfunction or danger. If the mains plug is not readily accessible due to mounting in a 19" rack or equipment cabinet, then the mains plug for the entire rack or cabinet must be readily accessible.
- Do not connect or disconnect the mains plug under load.

Before connecting the device to mains voltage, check that the mains voltage and frequency correspond to the specifications on the rating label next to the mains connector socket on the rear panel of the unit.

Mains voltage range

100 to 240 VAC, ~50/60 Hz, 1300 W.

A powerCON® TRUE 1 TOP mains connector socket [1] is fitted on the rear panel and an appropriate power cord [1.1] is supplied.

Required mains configuration

An appropriate circuit breaker from the on-site power distribution system is required:

- 100 - 127 VAC ~ 50/60 Hz - 20 A_{max}. B- or C-frame type.
- 208 - 240 VAC ~ 50/60 Hz - 16 A_{max}. B- or C-frame type.

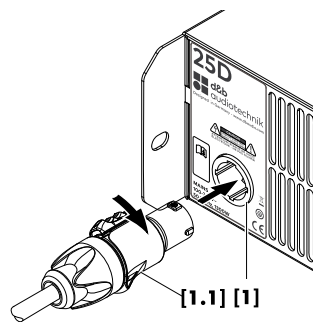
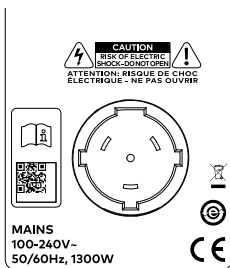

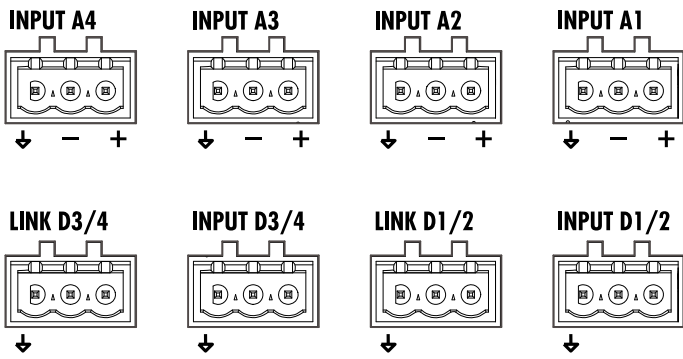

5.2.2 Audio INPUT and LINK/OUT connectors

The rear panel features eight installation specific Phoenix Euroblock connectors with the following assignments:

- Four analog inputs (A1 - A4) with corresponding link outputs.
- Two digital AES3 inputs (D1/2 and D3/4 - four channels) with corresponding outputs.

The digital inputs are fitted with permanent, high-speed, high-quality SRCs, thus AES3 signals from different sources and with differing sample rates can be processed without requiring any further user configuration.

Each input channel can be routed to any of the output channels A to D.

Analog INPUT (A1 - A4)

A 3-pin Phoenix Euroblock connector (male) is provided for each analog input to accept the supplied 3-pin Phoenix Euroblock connector (female). To feed (link) the input signal on to the next device in the signal chain, the connector can also be used as a cable tap.

Specifications

Pin assignment	(↓) GND, neg., pos.
Input impedance	32 kOhms, electronically balanced
CMRR @ 100 Hz/1 kHz/10 kHz	>80/>80/>70 dB
Maximum input level (balanced/unbalanced)	+25/+18 dBu
.....	+27.3 dBu @ 0 dBFS

Digital INPUT and LINK (D1/2 - D3/4)

A 3-pin Phoenix Euroblock connector (male) is provided for each pair of digital inputs to accept the supplied 3-pin Phoenix Euroblock connector (female).

The corresponding digital LINK output (1/2, 3/4) can be used to feed a refreshed input signal to the next device in the signal chain. The signal shape (the rising and falling edges of the signal) and level are refreshed with an analog buffer amplifier.

A power fail relay is incorporated to prevent interruption of the signal chain should there be a power failure. In this situation, the digital input signal bypasses the analog buffer amplifier and is routed directly to the LINK output.

Specifications

Pin assignment	(↓) GND, AES Signal, AES Signal
Input impedance	110 ohms, transformer balanced
Sampling frequency	44.1 48 96 192 kHz
Word length	16 - 24 bit
Digital LINK (D1/2, D3/4)	3-pin Phoenix Euroblock male
.....	electronically balanced
.....	analog signal buffering (refresh), power fail relay (Bypass)

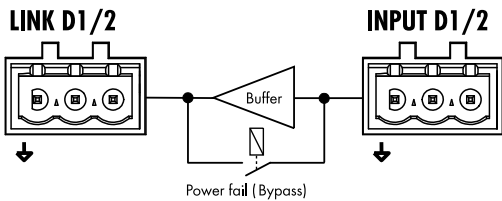

5.2.3 SPEAKER OUTPUTS



WARNING!
Potential risk of electric shock or fire.

Risk of electric shock

The amplifier output pins can carry dangerous voltages.

- Only use isolated loudspeaker cables with correctly fitted connectors.
- Never connect an amplifier output pin to any other input or output connector pin or protective earth (ground).
- **Bridge mode is not applicable.**

Risk of fire

To avoid any heating of the output connector terminal (glowing contact), the wires need to be properly fitted to the output connector terminal.

- Only use the enclosed Euroblock connector terminals.
- Observe the maximum cross-section of 6 mm² (AWG 10).
- Ensure all contact screws are properly tightened.
- Ensure the fixing screws of the connector terminal are properly fitted to the output connector socket of the device.

The amplifier is equipped with two Phoenix Euroblock connector sockets (female), one for each pair of amplifier output channels (A/B, C/D).

All pins of both output connectors are hardwired and permanently driven using the following pin assignment.

SPEAKER OUTPUTS A (B, C, D)

+ = Amp A (B, C, D) pos.

– = Amp A (B, C, D) neg.

Note: For further information regarding the applicable output modes for each loudspeaker system, please refer to the relevant loudspeaker manual.

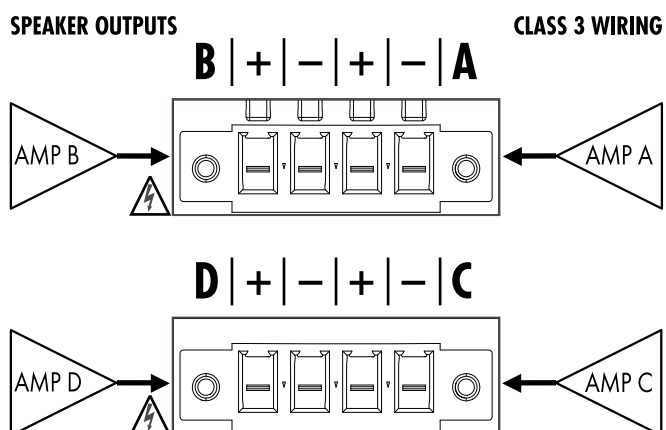

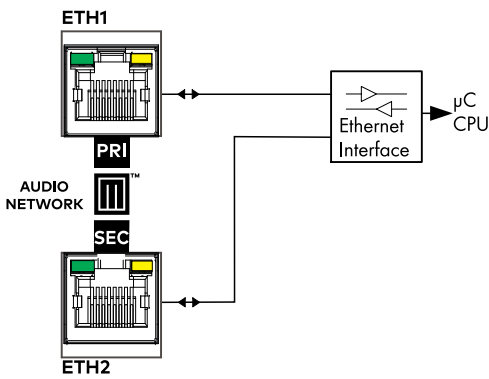

Milan secondary
ETH 2/SEC

Gbit Ethernet (star topology)

ETH1/PRI
Milan primary
Remote (R1)

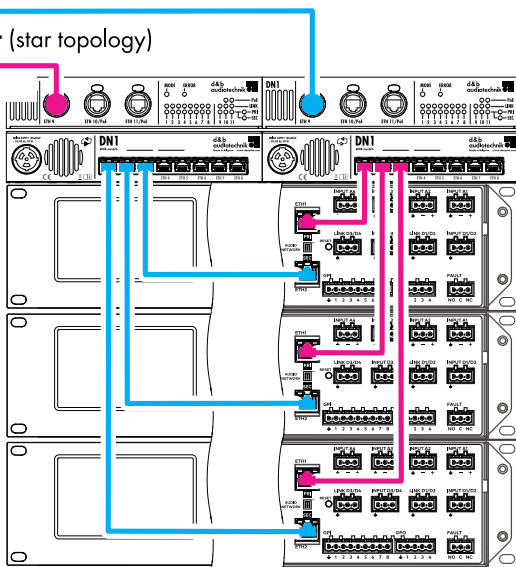

5.2.4 ETHERNET (Dual Ethernet port)

NOTICE!

Only **shielded network** cables (**STP**) must be used!

The device allows remote control as well as redundant digital audio networking (Milan™) via Ethernet. For this purpose, a Dual Ethernet port (1 Gbit/s/100 Mbit/s – peer-to-peer) is provided requiring star topology network wiring. Daisy-chaining is not supported.

For standard remote control via the d&b Remote network using the d&b R1 Remote control software or the integrated Web remote interface, **the upper RJ45 (ETH1/PRI)** connector socket is used.

This connector socket is also used for the primary (**PRI**) Milan™ signal while the bottom RJ45 connector socket (**ETH2/SEC**) is used for the redundant Milan™ signal only.

LED indicators

The two LED indicators above the respective connector in use indicate the following states:

- Green** ■ Illuminates permanently when the device is connected to an active network and flashes as long as a data stream is transmitted.
- Yellow** ■
 - Is off when the speed is 100 Mbit/s.
 - Illuminates permanently when the speed is 1 Gbit/s.

5.2.5 GPI/GPO (Hardware description)

Up to eight opto-coupled GPI pins [5] (General Purpose Input) and up to four GPO pins [6] (General Purpose Output) are available as additional digital control lines. This enables external control and detection functions.

Note: A detailed description of how to configure the GPIOs and assign the available software objects (functions) correspondingly is given in the 25D Reference manual, which can be downloaded from the related product page at www.dbaudio.com.

Each GPI provides either level (Hi/Lo active - non-latching) or edge (rising/falling - latching) triggering.

Note: When using a GPI or GPO contact, observe the following:

- An external DC power supply is required.
 - **GPI:** The corresponding pin is connected via an opto-coupler with a serial resistance of 5.4 kΩ.
 - **GPO:** The corresponding pin is connected to ground (GND/↓) via a relay (Low-Side-Switch).
- Make sure the current per GPO pin does not exceed 1 A.

Technical specifications

External power supply 24 VDC ±25% (18 - 30 VDC)/150 W

GPI 8 x Opto-coupled (galvanic isolation)
 High-level 18 ... 30 VDC
 Low-level 0 ... 9 VDC
 Serial resistance 5.4 kOhms
 Forward voltage drop ($U_{f(max)}$) 3.7 V
 Input current draw per pin @ 9/18/24/30 VDC
 1.5/2.6/3.7/4.8 mA
 Connector type 1 x 9-pin Phoenix Euroblock male
 Pin assignment (↓) GND, GPIs 1 - 8

GPO 4 x Low-Side-Switch-Relay
 High-state Closed (connected to common GPO GND)
 Low-state Open (high resistive)
 Max. current draw 1 A/Total: 4 A
 Connector type 1 x 5-pin Phoenix Euroblock male
 Pin assignment (↓) GND, GPOs 1 - 4

5.2.6 FAULT

An additional 3-pin Phoenix Euroblock fault contact [7] is provided allowing a general device error to be remotely indicated.

Note:

- The assignment of the corresponding software object is fixed and cannot be changed by the user.
- During a firmware update, the fault contact switches to status **b)**, as shown in the graphic opposite.

NO Normally Open
C Common
NC Normally Closed

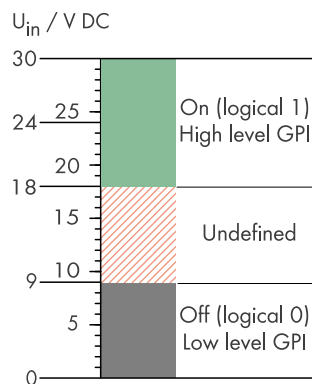
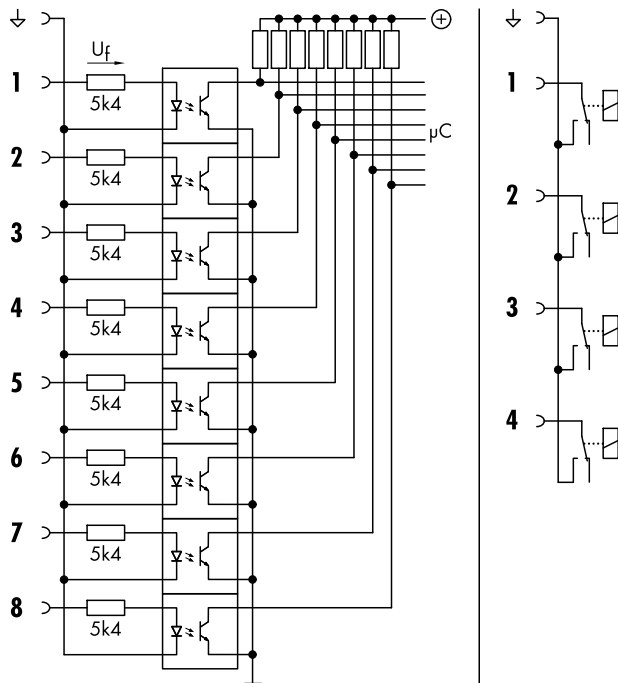
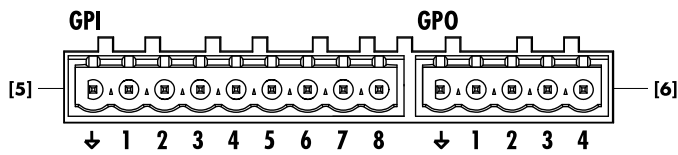

GPI | GPO

Schematic circuit diagrams and logic level chart (GPI)

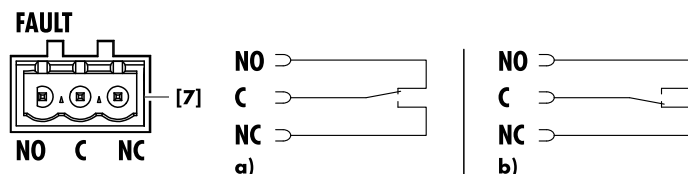

FAULT

Schematic circuit diagram and switching status:

- a) Device is On and operating
- b) Device is Off or general device error

5.3 Controls and indicators

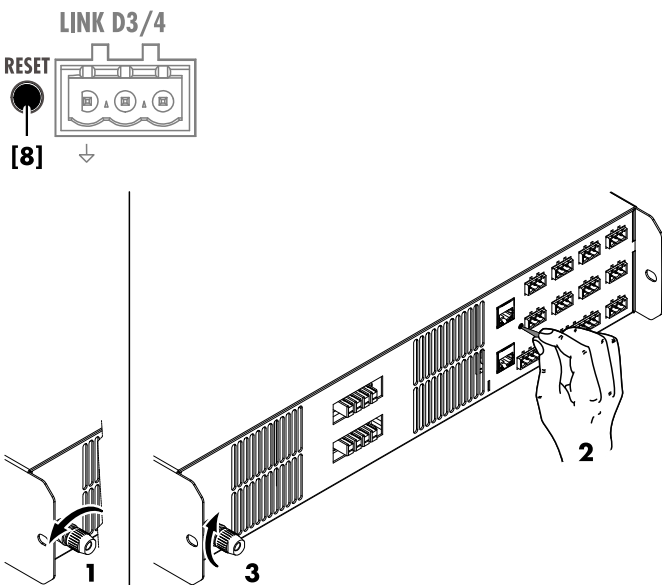

5.3.1 RESET (System reset)

A reset button (RESET [8]) is located on the rear panel next to the digital LINK D3/D4 connector terminal.

To prevent accidental system reset, the button is slightly recessed.

To perform a system reset, proceed as follows:

Note: All device settings will be set to factory defaults except for the network and fixed device settings such as AmpPresets. If you execute this procedure, no dialog will be prompted and the reset will start immediately.

1. Isolate the device from mains power by releasing the powerCON connector and turn it counterclockwise.
2. Press and hold the «RESET» button using an appropriate pen.
3. While holding the «RESET» button pressed, repower the device by turning the powerCON connector clockwise.
 - ↳ Long confirmation beep.
4. Release the «RESET» button and briefly press the button again within 2 sec.
 - ↳ Short confirmation beep ⇒ the device will reboot.

5.3.1.1 Network reset option (IP settings)

Executing the following reset procedure allows you to locally change/edit the network (IP) settings, if required.

Once the settings have been changed and the device has been shut down, the access to the network settings will be disabled again after repowering the device.

1. During normal operation, press and hold the «RESET» button for 5 sec.
 - ↳ Long confirmation beep.
2. Release the «RESET» button and briefly press the button again within 2 sec.
 - ↳ Short confirmation beep.

The network settings will become accessible for editing by tapping the «Network» navigation button as shown in the graphic opposite.

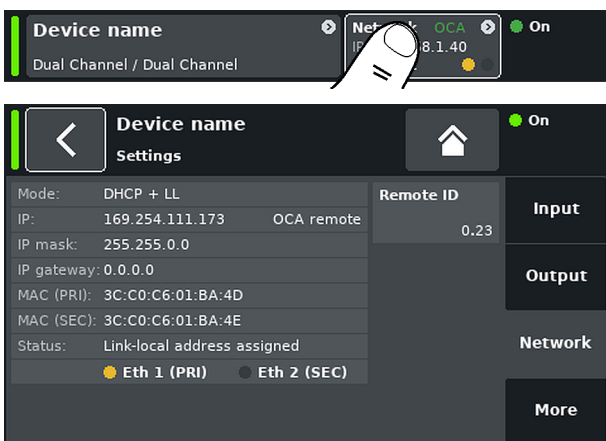

5.3.2 TFT color touchscreen - User interface

NOTICE!

The touch panel utilizes a thin flexible sheet that may be damaged by sharp objects or heavy treatment.

The user interface consists of a 4.3" TFT color touchscreen [9] with a resolution of 480 x 272 pixels.

The resistive touchscreen responds to pressure and therefore can be operated by a fingertip, even when wearing gloves or by an appropriate stylus tip (pen).

Screen contents

The display provides comprehensive information regarding the channel settings/statuses as well as the device settings/statuses.

The structure of the screen content(s) is divided into two main axes, the «Home» view, including the «Channel» settings/statuses, and the «Device» settings/statuses views.

Note: A detailed description on the screen contents is given in the 25D Reference manual which can be downloaded from the related product page at www.dbaudio.com.

Accessing the screen contents

⇒ To access a particular subscreen, simply tap  the corresponding screen item, shown as an example in the graphic below.

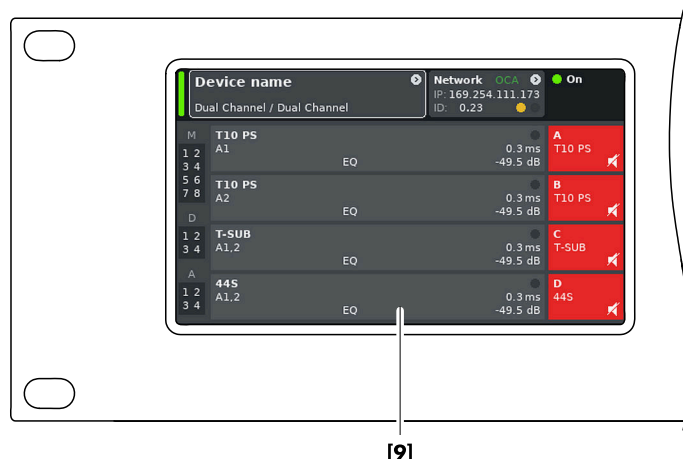

Screen access and structure chart

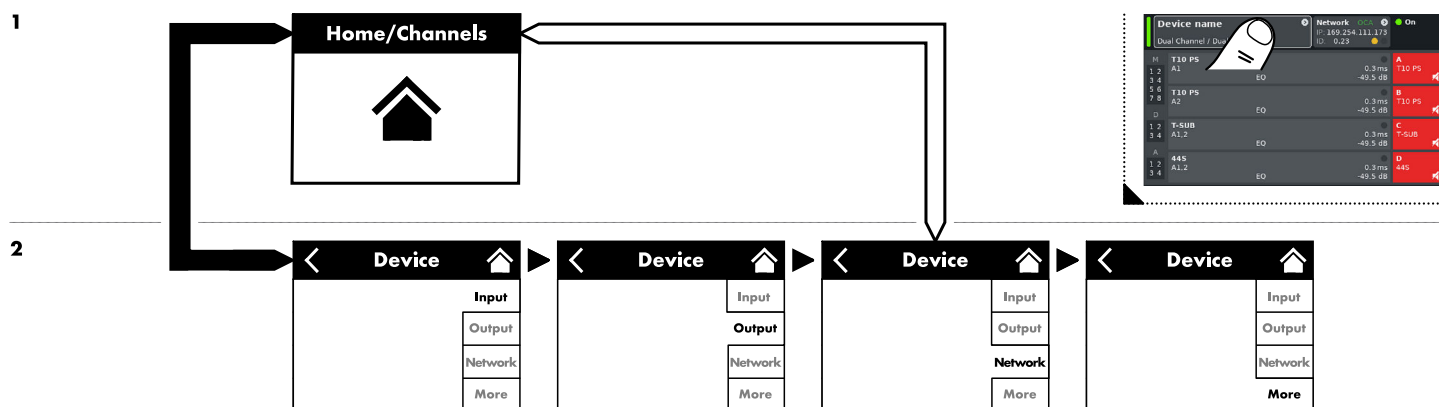

6.1 Initial device setup

The device is mainly intended to be set up and operated via the d&b Remote network using the d&b R1 Remote control software.

Provided R1 is already installed and the device has been connected either directly or through the network, proceed as follows:

⇒ From the startup menu, choose the «R1 V3 Initial device setup» entry.

↳ R1 is launched and automatically switches to «Online» mode and the «Service» view is displayed.

In the left pane of the view, the connected device is listed.

In the right pane, the corresponding «Filter» ⇒ «Initial device setup» is set by default and provides you with basic parameters (in alphabetical order) to set up the device.

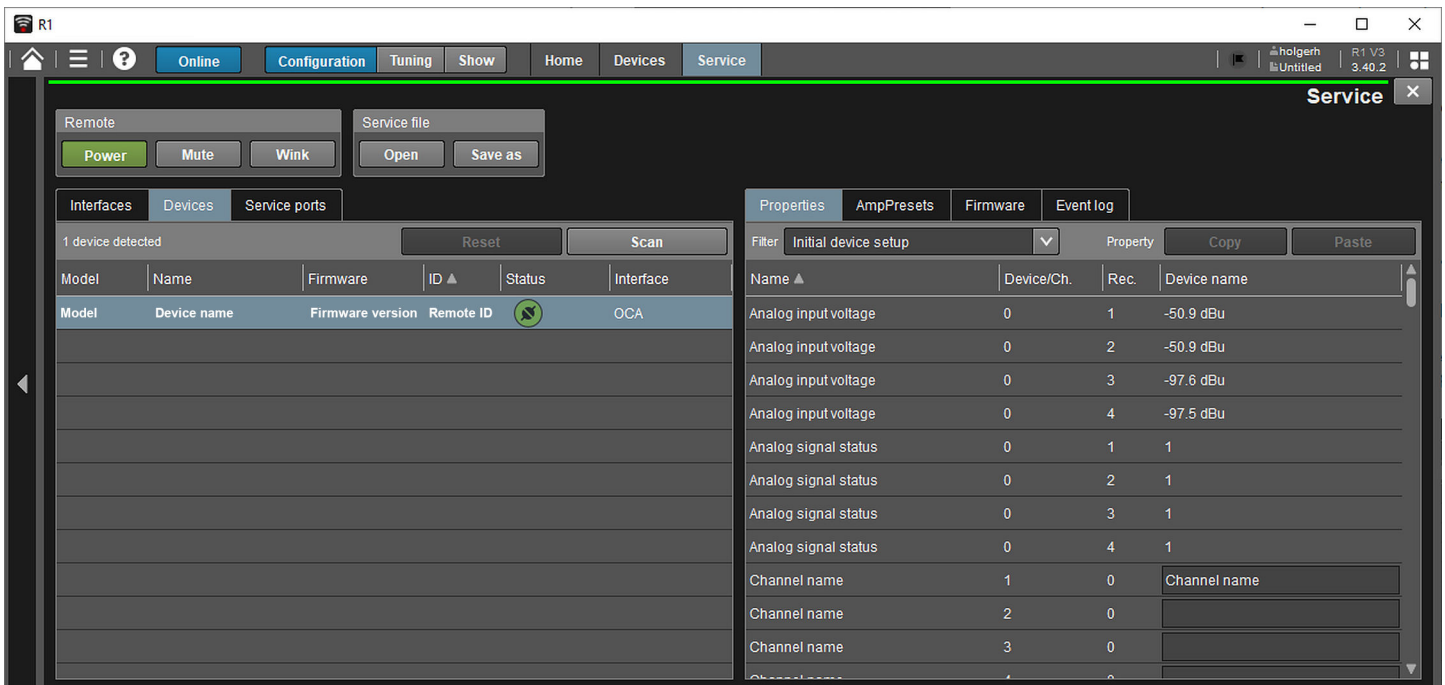

7.1 Service



CAUTION!

Potential risk of explosion.

The device incorporates a lithium battery which may cause danger of explosion if not replaced correctly.

Refer replacement only to qualified service personnel authorized by d&b audiotechnik.

Do not open the device. No user serviceable parts inside. In case of any damage do not operate the device under any circumstances.

Refer servicing only to qualified service personnel authorized by d&b audiotechnik. In particular if:

- objects or liquids have entered the device.
- the device does not operate normally.
- the device was dropped or the housing is damaged.

7.2 Maintenance and care

During normal operation, the amplifier provides maintenance-free service.

Due to the cooling concept, no dust filters are required. As a result, filter exchange or cleaning the filters is not necessary.

However, the air-intake is covered by a grill which should be regularly cleaned (vacuumed) using an appropriate vacuum cleaner.

7.2.1 Touchscreen cleaning

After a certain period of time, the touchscreen may require cleaning.

For this purpose, proceed as follows:

- Use a soft cloth only.
- Do not use any solvent cleaners.

To remove very heavy dirt from the panel, it may be helpful to use a special cleaning spray for TFT screens. In this case, proceed as follows:

1. Spray on the soft cloth before wiping the screen.
 - ↳ Never apply/spray directly on the screen as the liquid could penetrate the device.
2. Wipe the screen with moderate pressure.

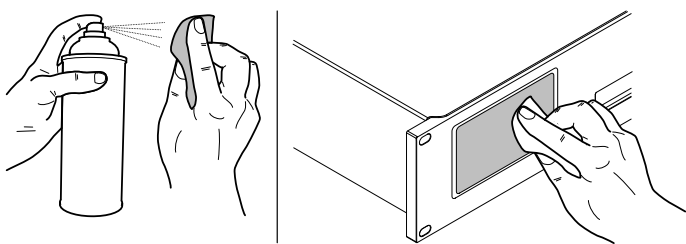
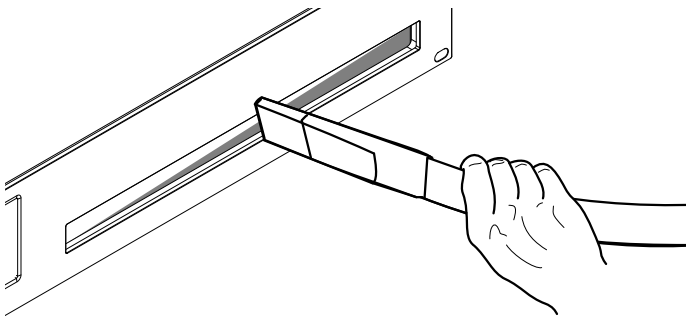



8.1 Declaration of Conformity

This declaration applies to:

d&b Z2810 25D Amplifier

by d&b audiotechnik GmbH & Co. KG.

All product variants are included, provided they correspond to the original technical version and have not been subject to any later design or electromechanical modifications.

We herewith declare that said products are in conformity with the provisions of the respective directives including all applicable amendments.

Detailed and applicable declarations are available on request and can be ordered from d&b or downloaded from the d&b website at www.dbaudio.com.



8.2 WEEE Declaration (Disposal)

Electrical and electronic equipment must be disposed of separately from normal waste at the end of its operational lifetime.

Please dispose of this product according to the respective national regulations or contractual agreements. If there are any further questions concerning the disposal of this product, please contact d&b audiotechnik.

WEEE-Reg. -Nr. DE: 13421928

8.3 Licenses and Copyright

A list of the components and a full-text version of all licenses and copyrights can be accessed using the amplifier's Web Remote interface.

⇒ Selecting the d&b logo at the top left of the «Web Remote» interface page allows access to the «Licenses and Copyright» information page.

This page provides an overview of the open source software used in this product. As required by the GPL and LGPL licenses, we will send you a copy of the used source code on request. If you would like to obtain a copy, please contact us by mail to: software.support@dbaudio.com

