

D

D90
Start-up manual
1.2 en

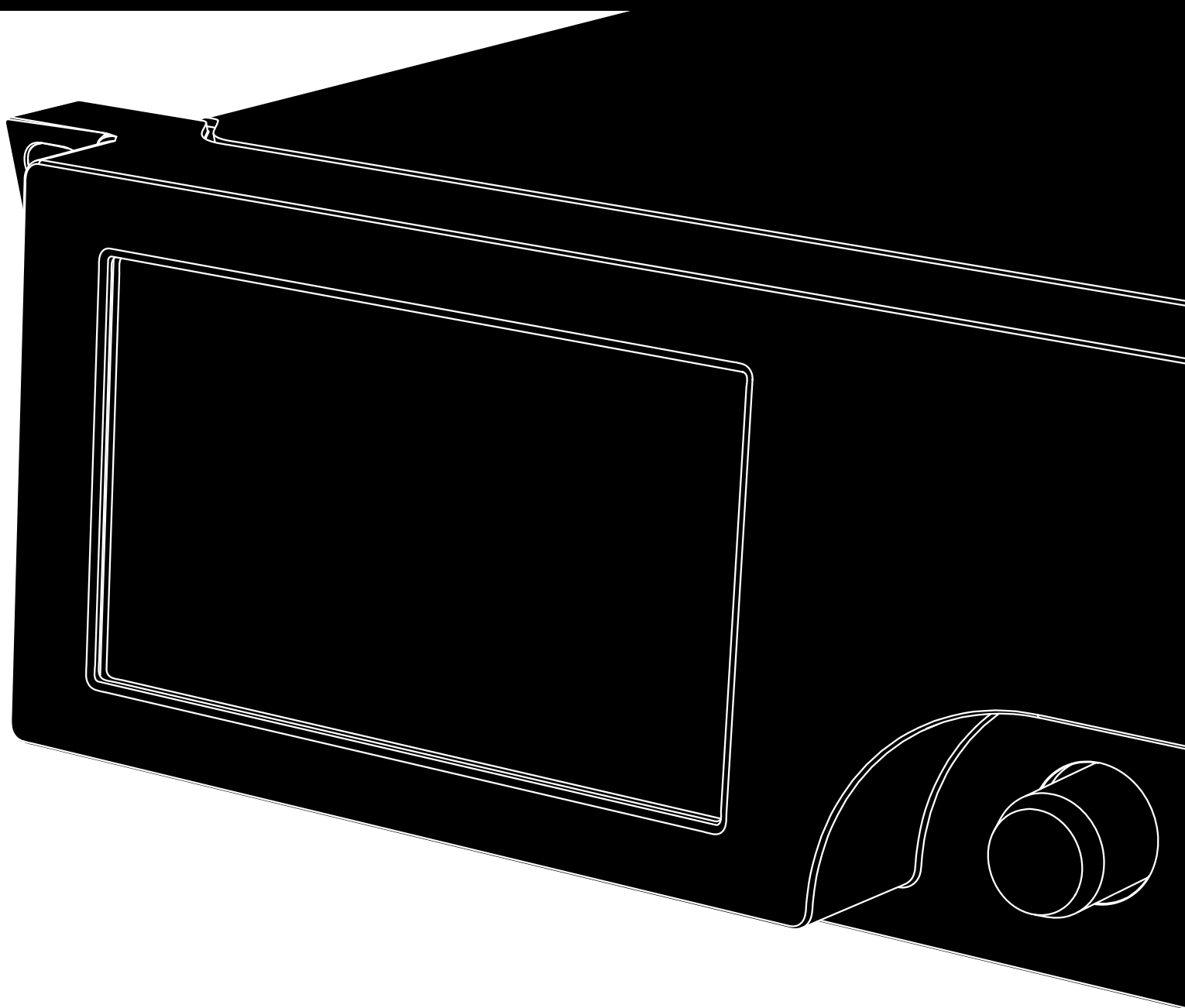

Notes on document version

All previous versions of this document are hereby no longer valid.

Version 1.2:

Milan™ version.

General information

D90 Start-up manual

Version: 1.2 en, 04/2025, D2090.EN .01

Copyright © 2025 by d&b audiotechnik GmbH & Co. KG; all rights reserved.

Keep this document with the product or in a safe place so that it is available for future reference.

We recommend you to regularly check the d&b website for the latest version of this document.

When reselling this product, hand over this document to the new owner.

If you supply d&b products, please draw the attention of your customers to this document. Enclose the relevant documents with the systems. If you require additional documents for this purpose, you can order them from d&b.

d&b audiotechnik GmbH & Co. KG
Eugen-Adolff-Str. 134, D-71522 Backnang, Germany
T +49-7191-9669-0, F +49-7191-95 00 00
docadmin@dbaudio.com, www.dbaudio.com

Explanation of graphical symbols



The lightning symbol within a triangle is intended to alert the user to the presence of uninsulated "dangerous voltages" within the unit's chassis that may be of sufficient magnitude to constitute a risk of electric shock to humans.



The exclamation point within a triangle is intended to alert the user to the presence of important operating and service instructions in the literature accompanying the product.

Before using this product, carefully read the applicable items of the following safety instructions.

1. Keep these instructions for future reference.
2. Read these instructions.
3. Heed all warnings.
4. Follow all instructions.
5. **WARNING!** To reduce the risk of fire or electric shock:
 - Do not expose this unit to rain or moisture.
 - Keep water or other liquids away from the unit.
 - Do not place liquid filled containers, for example beverages, on top of the unit.
 - Do not operate the unit while it is wet or standing in liquid.
6. Always operate the unit with the chassis ground wire connected to the electrical safety earth.
Do not defeat the safety purpose of a grounding-type plug. A grounding-type plug has two blades and a third grounding prong. The third prong is provided for your safety. If the provided plug does not fit into your outlet, consult an electrician for replacement of the obsolete outlet.
7. Do not use this unit if the power cord is damaged or frayed. Protect the power cord from being walked upon or pinched, particularly at the plugs and the point where it exits from the apparatus.
8. The unit is intended for use in a 19" rack. Follow the mounting instructions. When a rack on wheels is used, exercise caution when moving the loaded rack to avoid injury from tipping over.
9. Unplug this apparatus during lightning storms or when unused for long periods of time.
10. Never connect an output pin to any other amplifier input or output pin or to the earth (ground). This may damage the unit or lead to electric shock.
11. Lay all cables connected to the unit carefully so that they cannot be crushed by vehicles or other equipment and that no one can either step on them or trip over them.
12. Refer all servicing to qualified service personnel. Servicing is required when the apparatus has been damaged in any way such as:
 - Power-supply cord or plug is damaged.
 - Liquid has been spilled into the unit.
 - An object has fallen into the unit.
 - The unit has been exposed to rain or moisture.
 - The unit does not operate normally.
 - The unit was dropped or the chassis is damaged.
 - Do not remove top or bottom covers. Removal of the covers will expose hazardous voltages. There are no user serviceable parts inside and removal may void the warranty.
13. Use the mains plug as the disconnecting device and keep it readily accessible. If the mains plug is not readily accessible due to mounting in a 19" equipment cabinet, then the mains plug for the entire rack must be readily accessible.
14. An experienced user must always supervise the equipment, especially if inexperienced adults or minors are using the equipment.

WARNINGS!



To prevent electric shock do not remove top or bottom covers. No user serviceable parts inside, refer servicing to qualified service personnel.

Français : À prévenir le choc électrique n'enlevez pas les couvercles. Il n'y a pas des parties serviceable à l'intérieur, tous reparations doit être faire par personnel qualifié seulement.



To completely disconnect this equipment from the AC mains, disconnect the power supply cord plug from the AC receptacle. The mains plug of the power supply cord shall remain readily operable.

Français : Pour démonter complètement l'équipement de l'alimentation générale, démonter le câble d'alimentation de son réceptacle. La prise d'alimentation restera aisément fonctionnelle.



To reduce risk of fire or electric shock, do not expose this apparatus to rain or moisture.

Français : Pour réduire les risques d'incendie ou de choc électrique, n'exposez pas l'appareil à la pluie ou à l'humidité.



Do not expose this system/apparatus to dripping or splashing and ensure that no objects filled with liquids, such as vases, are placed on the apparatus.

Français : N'exposez pas ce système/appareil au ruissellement ni aux éclaboussures et assurez-vous qu'aucun objet contenant du liquide tel qu'un vase n'est placé sur l'appareil.



This apparatus must be connected to a mains socket outlet with a protective earthing connection.

Français : Cet appareil doit être raccordé à une prise secteur avec terre de protection.



The mains plug is used as a disconnect device and shall remain readily operable.

Français : Lorsque la prise du réseau d'alimentation est utilisés comme dispositif de déconnexion, ce dispositif doit demeuré aisément accessible.

CAUTION!



To reduce the risk of fire or electric shock, do not remove screws. No user-serviceable parts inside. Refer servicing to qualified service personnel.

Français : Pour réduire le risque d'incendie ou de choc électrique, ne pas retirer les vis. Aucune pièce réparable par l'utilisateur. Confier l'entretien à personnel qualifié.

1	Intended use	6
1.1	About this manual.....	6
1.2	Loudspeaker types.....	6
2	Scope of supply	7
3	Technical specifications	8
3.1	Current/power draw and thermal dissipation.....	11
4	Overview	13
4.1	Connections.....	13
4.2	Controls and indicators - User interface.....	13
5	Startup	14
5.1	Rack mounting and cooling.....	14
5.2	Connections.....	15
5.2.1	Mains connection.....	15
5.2.2	Audio INPUT and LINK/OUT connectors.....	16
5.2.3	SPEAKER OUTPUTS.....	17
5.2.4	Network connections.....	18
5.3	Controls and indicators.....	19
5.3.1	Mains power switch.....	19
5.3.2	TFT color touchscreen - User interface.....	19
5.3.2.1	Operating concept.....	20
5.3.2.2	Standby mode.....	22
5.3.2.3	Mute functions.....	23
6	Basic settings - Quick reference	24
7	Service/Maintenance and care	26
7.1	Service.....	26
7.2	Maintenance and care.....	26
7.2.1	Touchscreen cleaning.....	26
7.2.2	Touchscreen calibration.....	27
8	Manufacturer's declarations	28
8.1	Declaration of Conformity.....	28
8.2	WEEE Declaration (Disposal).....	28
8.3	Licenses and Copyright.....	28

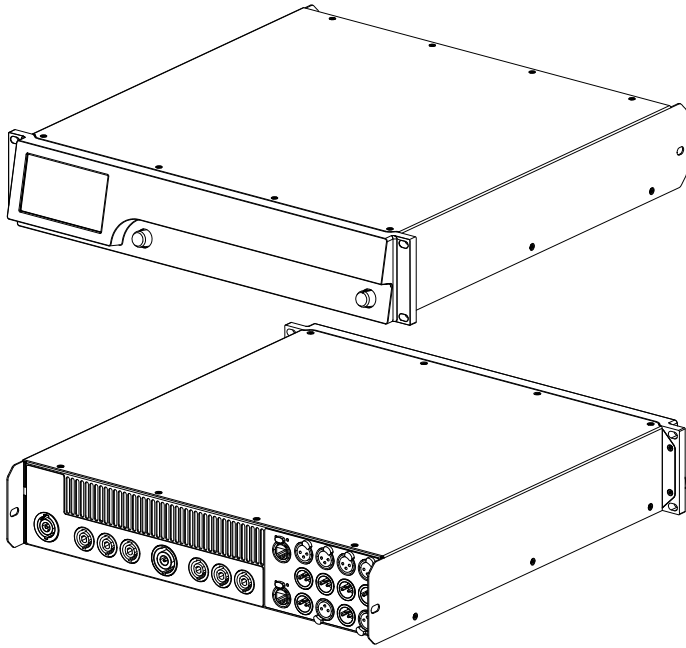

The d&b D90 amplifier is designed for mobile applications and is intended to be used with applicable d&b loudspeakers.

A "LINEAR" setup is available allowing the amplifier to be used as a linear power amplifier.

Note: d&b audiotechnik will accept no liability for any damages to third-party loudspeakers when operated with d&b amplifiers in "LINEAR" mode.

NOTICE!

The device complies with the electromagnetic compatibility requirements of EN 55032:2019 (product family standard for audio, video, audio-visual and entertainment lighting control apparatus for professional use) for the environment Class B (residential).

Acoustic interferences and malfunctions may occur if the unit is operated in the immediate vicinity of high-frequency transmitters (e.g. wireless microphones, mobile phones, etc.). Damage to the device is unlikely, but cannot be excluded.

1.1 About this manual

With respect to the vast functionality and high complexity of the device, this manual covers the basic safety instructions as well as the vital technical specifications and instructions for startup.

A full version of this manual in English language (⇒ Reference manual) with comprehensive information is available for download on the related product page of the d&b website at www.dbaudio.com.

1.2 Loudspeaker types

The maximum number of cabinets driven by each channel varies depending on their nominal impedance. It can be found in the respective loudspeaker manual and also in the data section of each loudspeaker product page on the d&b website at www.dbaudio.com.

The minimum recommended impedance per channel is 4 ohms.

Nom. impedance	Cabinets per channel
4 Ω	1
8 Ω	2
12 Ω	3
16 Ω	4
20 Ω	5

A list of d&b loudspeakers supported by the amplifier is included in the Release notes of the amplifier firmware. The latest version can be found on the related product page of the d&b website at www.dbaudio.com.

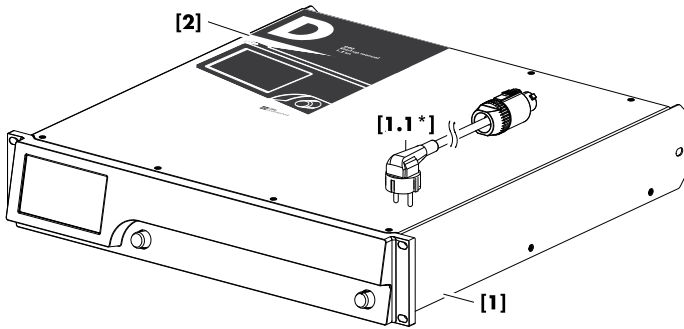

Before starting up the device, please verify the shipment for completeness and proper condition of the items.

If there is any sign of obvious damage to the unit and/or the power cord, do not operate the unit and contact your local dealer from whom you received it.

Pos.	Qty.	d&b Code	Description
[1]	1	Z2860	d&b D90 Amplifier
Including:			
[1.1*]	1	Z2620.xxx	Power cord (specific to country*)
[2]	1	D2090.EN .01	d&b D90 Start-up manual.

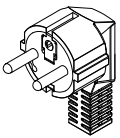

Z2620.000
3-pin Schuko
CEE 7/7

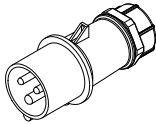

Z2620.001
3-pin Denmark
IEC 60309

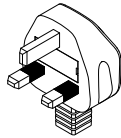

Z2620.010
3-pin GB
BS 1363A

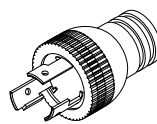

Z2620.020
3-pin USA
NEMA L5-30P

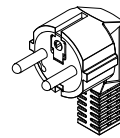

Z2620.040
3-pin South Korea
KS C8305

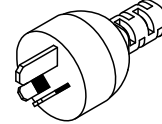

Z2620.050
3-pin Australia
AS 3112

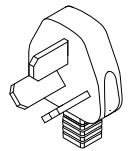

Z2620.060
3-pin China
GB 2099

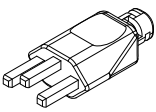

Z2620.070
3-pin Swiss
SEV1011/T23

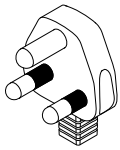

Z2620.100
3-pin South Africa
SANS 164-1

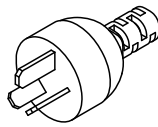

Z2620.111
3-pin Argentina
IRAM 2073

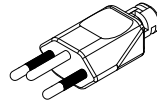

Z2620.120
3-pin Brazil
NBR 14136

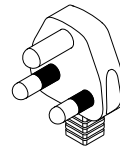

Z2620.130
3-pin India
IS 1293

* Mains plug types and associated standards
(Similar illustrations, not in scale)

Operating conditions

Operating temperature (*continuous/**short-term)
.....	-10 °C ... +40*/+50** °C (+14 °F ... +104*/+122** °F)
Storage temperature -20 °C ... +70 °C (-4 °F ... +158 °F)
Humidity (rel.), non-condensating < 70 %
Maximum height above sea level 2000 m/6560 ft

Power supply

Switched mode power supply with automatic mains range selection and active Power Factor Correction (PFC).

Mains connector powerCON-HC®
Mains fuse internal
Rated mains voltage (High range) 208 - 240 V, 50 - 60 Hz
Rated mains current (High range) 16 A
Rated mains voltage (Low range) 100 - 127 V, 50 - 60 Hz
Rated mains current (Low range) 30 A

Protection circuits

Mains and power supply: Overvoltage and undervoltage, inrush current limiter, internal fuse.

Output: Overcurrent, DC offset, HF voltage limiter, pop-noise suppression.

Cooling: Temperature-dependent RPM of fan, self-resetting overtemperature protection.

Power consumption (typical values)

Standby 24 W
Idling 160 W
Peak output 3650 W

Audio power outputs *

SPEAKER OUTPUTS A/B/C/D 4 x NL4
SPEAKER OUTPUTS A/B MIX 2-WAY / C/D MIX 2-WAY 2 x NL4
4 CHANNEL OUTPUT 1 x NL8
Maximum output voltage/current 210 V _{peak} /78 A _{peak}
Output power rating EIA-426B noise CF 12 dB 4 x 2700 W/8 Ω
.....	4 x 5400 W/4 Ω
Sine wave 1 kHz, long term, +40 °C (+104 °F) 4 x 450 W/4 Ω
Frequency response (-1 dB, Linear mode) 35 Hz - 25 kHz
Gain (Linear mode @ 0 dB) 31 dB

Output noise/Dynamic range

Output noise (BW 20 kHz)/dynamic range (BW 20 kHz, reference 210 V _{pk})
Analog input 235 μV _{RMS} /116 dB
Analog input, A-weighting 185 μV _{RMS} /118 dB
Digital/Milan input 170 μV _{RMS} /119 dB
Digital/Milan input, A-weighting 135 μV _{RMS} /121 dB

THD+N/Crosstalk

THD+N (unweighted, 20 - 20 kHz)
4 x 450 W/8 ohms < -80 dB/0.01 %
4 x 450 W/4 ohms < -74 dB/0.02 %
Crosstalk (20 - 20 kHz) < -70 dB
.....	4 x 450 W into 8/4 Ω

Analog inputs and outputs

INPUT A1 - A4 3 pin XLR female
Pin assignment 1 = GND, 2 = pos., 3 = neg.
Input impedance 32 kΩ, electronically balanced
CMRR @ 100 Hz/1 kHz / 10 kHz >80/>80/>70 dB
Maximum input level (balanced/unbalanced) +25/+18 dBu
.....	+27.3 dBu @ 0 dBFS
LINK A1 - A4, parallel to input 3 pin XLR male
Pin assignment 1 = GND, 2 = pos., 3 = neg.

Digital inputs and outputs

IN - D1/2, D3/4 3 pin XLR female, AES3
Pin assignment 1 = GND, 2 = AES Signal, 3 = AES Signal
Input impedance 110 Ω, transformer balanced
Sampling frequency 44.1 48 96 192 kHz
Word length 16 - 24 bit
OUT - D1/2, D3/4 3 pin XLR male
.....	electronically balanced
Output modes Mains on: analog signal buffering (refresh)
.....	Mains off/power fail: bypass relay

Milan™ inputs

Device type Endstation
Input channel streams 1 stream with up to 8 channels @ 48/96 kHz
Redundancy Yes (always)
Routable Milan™ inputs M1-8

Network connections

Connector type 2 x RJ 45 (etherCON®)
Switch integrated 2-port, 1 Gbit/100 Mbit
IP address/Subnet mask 192.168.1.90/255.255.255.0
ETH1/PRI Milan™, Remote control via R1 star topology
ETH2/SEC Milan™ redundancy only, no remote control star topology

Digital Signal Processing

System start-up time < 45 sec.
Time to tone (Standby/ReadyStandby) < 4/< 1 sec.
Time to tone (Off/Wake on Audio) < 45 /< 4 sec.
Conversion 96 kHz
Latency analog/digital (AES) input 0.3/0.3 msec.
A/D conversion 27 Bit (dual-stacked A/D converters)
Internal processing Combination of high-resolution fixed point and floating point processing
Equalizer two user definable 16-band equalizers
.....	Filter types: PEQ/Notch/HiShlv/LoShlv/Asym
Delay 0.3 msec. - 10 sec.
Frequency generator Pink noise or Sine wave 10 Hz - 20 kHz

Controls and indicators

POWER Mains power switch
SCROLL/EDIT Digital rotary encoder
TFT color touchscreen 4.3"/480 x 272 pixels

Fan noise emission

Rack mounted, measured on axis, 1 m (3.3 ft) to front panel, A-weighting.
 Min./Max. RPM 27/50 dB(A)
 Ambient temperature 23 °C/73.4 °F

Dimensions and weight

Height x width x depth 2 RU x 19" x 512 mm (20.2")
 Weight 18.8 kg/41.5 lb

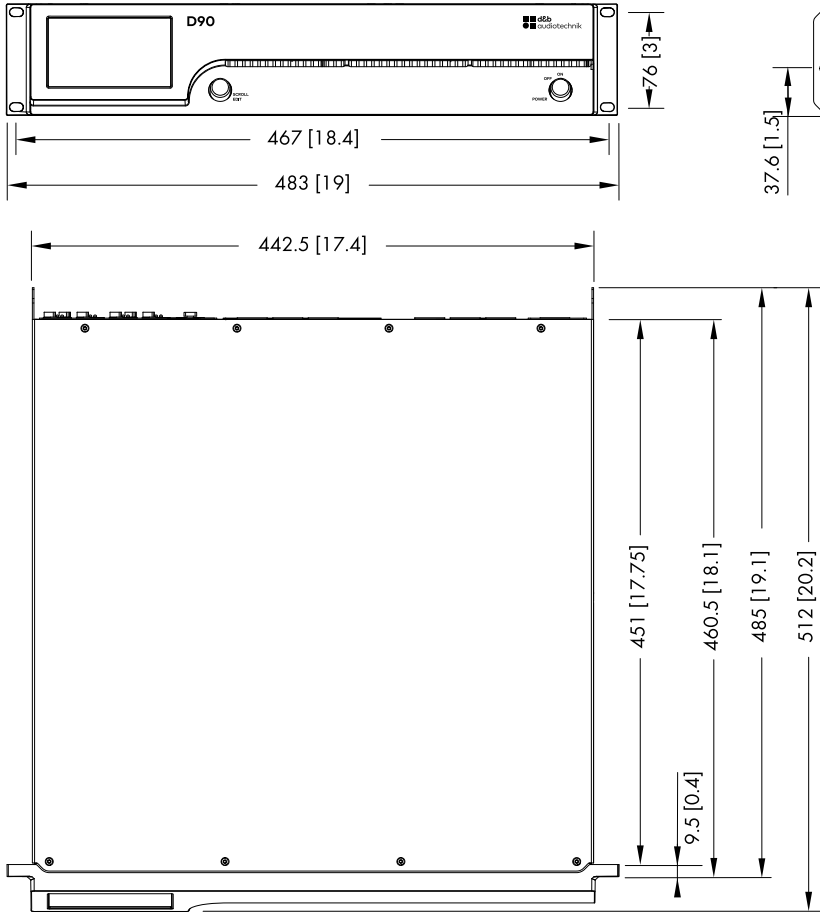

D90 enclosure dimensions in mm [inch]

*** Audio power output – Measurement references:**

All data is valid for 23 °C (73.4 °F) ambient temperature and 230 VAC/50 Hz mains supply.

The power rating of noise signals is defined as the maximum of the instantaneous output power divided by a factor of two.

The power of burst signals refers to the power during the "on" period.

The duration of the peak output of a sine wave signal is defined at a drop of 0.5 dB/10% relative to the maximum output power.

EIA-426B noise			
Crest factor	Load [ohms]	Power rating [W]	Power average [W]
12 dB	8	4 x 2700	4 x 337.5
	4	4 x 5400	4 x 675
9 dB	8	4 x 2700	4 x 675
	4	4 x 2700	4 x 675
6 dB	8	4 x 1450	4 x 725
	4	4 x 1400	4 x 700
1 kHz burst			
On/off time	Load [ohms]	Power [W]	
20 ms/0 dB 480 ms/-20 dB	8	4 x 2200	
	4	4 x 2800	
200 ms/0 dB 600 ms/-20 dB	8	4 x 1450	
	4	4 x 1450	
1 kHz sine wave			
Channels used	Load [ohms]	Max. output power [W]	Duration of max. output
1	8	1 x 2700	> 10 s
	4	1 x 5400	2.2 s
4	8	4 x 2700	6 ms
	4	4 x 5400	3 ms

Measurement references

For all noise signals, the values are measured at the maximum level just before any amplifier limiter activity (no Gain Reduction).

Noise CF 12 dB: Noise signal according to EIA-426-B with a crest factor of 12 dB.
This represents the use case of live music or less compressed recorded music.

Noise CF 9 dB: Noise signal according to EIA-426-B with a crest factor of 9 dB.
This represents the use case of music with medium compression.

3.1 Current/power draw and thermal dissipation

Noise CF 6 dB: Noise signal according to EIA-426-B with a crest factor of 6 dB.

This represents the use case of heavily compressed music.

Sine wave (100 ms): 1 kHz sine wave signal, 0 dBFS input level and a duration of 1 s.

The RMS current value is calculated over a 100 ms time window. This window is stepped in increments of 10 ms over the recording. The resulting value is the highest current within a window of 100 ms.

230 V AC / 50 Hz / 0.5 Ω Source impedance - all channels driven								
State	Load [ohms]	Mains current [A RMS]	Power factor	Input power [W]	Output power [W]	Power loss [W]	BTU/hr	kCal/hr
Off	-	0.15	0.08	2.6	-	2.6	9	2
Standby	-	0.24	0.44	24.4	-	24.4	83	21
ReadyStandby	-	0.49	0.65	72.7	-	72.7	248	63
Eco	-	0.81	0.70	131	-	131	447	113
Idling	-	0.90	0.77	159	-	159	542	137
Noise CF 12 dB	8 4	7.9 15.5	0.97 0.98	1775 3475	1350 2700	425 775	1450 2644	366 667
Noise CF 9 dB	8 4	14.7 15.6	0.98 0.98	3350 3525	2700 2700	650 825	2218 2815	559 710
Noise CF 6 dB	8 4	15.8 16.0	0.99 0.99	3600 3650	2900 2800	700 850	2388 2900	602 731
Sine wave max. 1 s	8 4	34.6 34.1	- -	- -	- -	- -	- -	- -

208 V AC / 60 Hz / 0.5 Ω Source impedance - all channels driven								
State	Load [ohms]	Mains current [A RMS]	Power factor	Input power [W]	Output power [W]	Power loss [W]	BTU/hr	kCal/hr
Off	-	0.16	0.06	2.1	-	2.1	7	2
Standby	-	0.25	0.42	22.4	-	22.4	76	19
ReadyStandby	-	0.51	0.65	69.0	-	69.0	235	59
Eco	-	0.85	0.70	124	-	124	423	107
Idling	-	1.0	0.75	156	-	156	532	134
Noise CF 12 dB	8 4	8.8 15.9	0.97 0.98	1775 3225	1350 2450	425 775	1450 2644	366 667
Noise CF 9 dB	8 4	16.0 15.9	0.98 0.98	3275 3250	2625 2450	650 800	2218 2729	559 688
Noise CF 6 dB	8 4	15.9 16.0	0.99 0.99	3275 3300	2600 2450	675 850	2303 2900	581 731
Sine wave max. 1 s	8 4	33.7 33.3	- -	- -	- -	- -	- -	- -

120 V AC / 60 Hz / 0.2 Ω Source impedance - all channels driven								
State	Load [ohms]	Mains current [A RMS]	Power factor	Input power [W]	Output power [W]	Power loss [W]	BTU/hr	kCal/hr
Off	-	0.10	0.06	0.7	-	0.7	2	1
Standby	-	0.27	0.68	22.0	-	22.0	75	19
ReadyStandby	-	0.72	0.82	71.2	-	71.2	243	61
Eco	-	1.5	0.74	131	-	131	447	113
Idling	-	1.5	0.88	161	-	161	549	138
Noise CF 12 dB	4	15.5 29.9	0.97 0.98	1800 3500	1350 2625	450 875	1535 2985	387 753
Noise CF 9 dB	8 4	29.1 30.1	0.98 0.99	3425 3550	2700 2625	725 925	2474 3156	624 796
Noise CF 6 dB	8 4	29.2 29.8	0.99 0.99	3450 3525	2700 2600	750 925	2559 3156	645 796
Sine wave max. 1 s	8 4	68.8 68.0	- -	- -	- -	- -	- -	- -

100 V AC / 60 Hz / 0.2 Ω Source impedance - all channels driven								
State	Load [ohms]	Mains current [A RMS]	Power factor	Input power [W]	Output power [W]	Power loss [W]	BTU/hr	kCal/hr
Off	-	0.08	0.06	0.5	-	0.5	2	1
Standby	-	0.29	0.75	21.8	-	21.8	74	19
ReadyStandby	-	0.77	0.85	65.4	-	65.4	223	56
Eco	-	1.6	0.76	120	-	120	409	103
Idling	-	1.8	0.89	156	-	156	532	134
Noise CF 12 dB	8 4	18.9 30.1	0.98 0.98	1850 2950	1350 2100	500 850	1706 2900	430 731
Noise CF 9 dB	8 4	29.9 30.0	0.99 0.99	2925 2950	2200 2100	725 850	2474 2900	624 731
Noise CF 6 dB	8 4	29.8 39.8	0.99 0.99	2925 2925	2200 2050	725 875	2474 2985	624 753
Sine wave max. 1 s	8 4	69.6 69.2	- -	- -	- -	- -	- -	- -

4.1 Connections

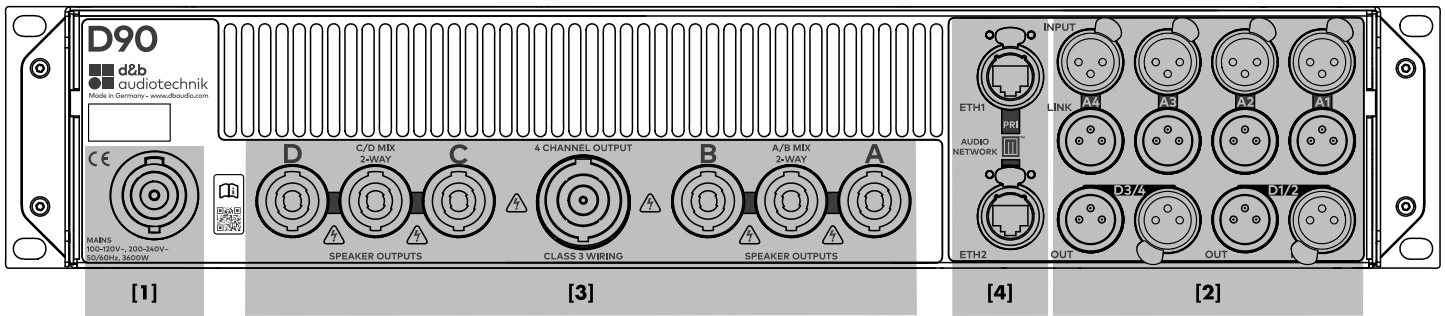
**[1]** Mains connector socket.

Refer to ⇒ Chapter 5.2.1 "Mains connection" on page 15.

[3] Output connector panel.

Refer to ⇒ Chapter 5.2.3 "SPEAKER OUTPUTS" on page 17.

[2] Audio INPUT (analog/digital) and LINK connectors.

Refer to ⇒ Chapter 5.2.2 "Audio INPUT and LINK/OUT connectors" on page 16.

[4] Network (PRI/SEC).

Refer to ⇒ Chapter 5.2.4 "Network connections" on page 18.

4.2 Controls and indicators - User interface

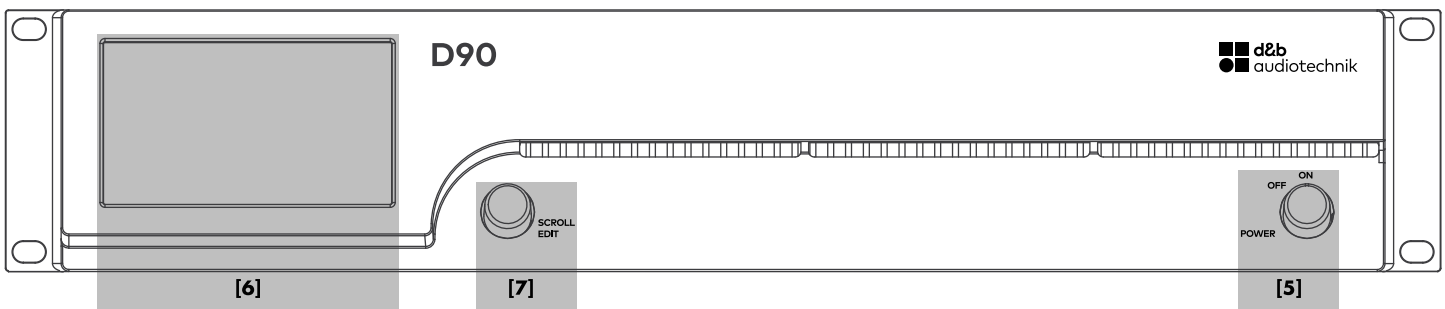
**[6]** TFT color touchscreen
4.3" / 480 x 272 pixels.**[7]** Rotary encoder SCROLL/EDIT.

Refer to ⇒ Chapter 5.3 "Controls and indicators" on page 19, following ⇒ Chapter 5.3.2 "TFT color touchscreen - User interface" on page 19.

[5] Mains power switch.

Refer to ⇒ Chapter 5.3 "Controls and indicators" on page 19, following ⇒ Chapter 5.3.1 "Mains power switch" on page 19.

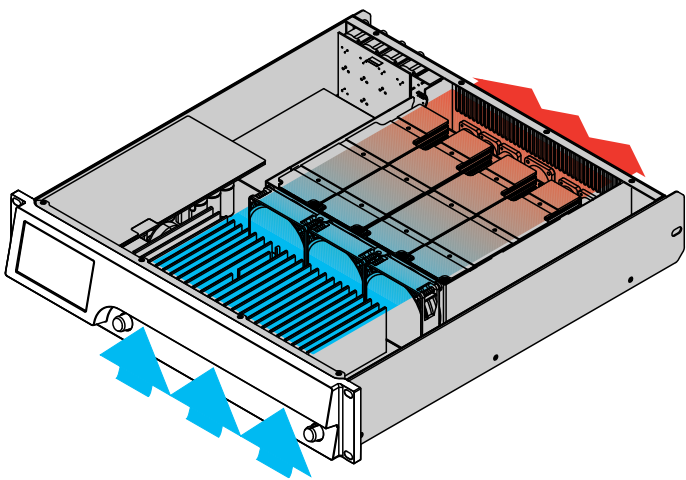
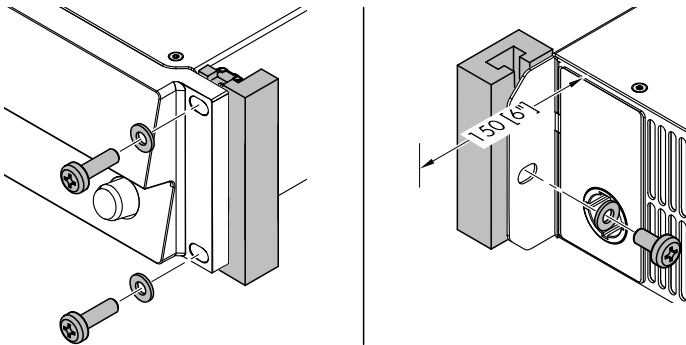

5.1 Rack mounting and cooling

Rack mounting

The enclosure is designed to fit standard 19" equipment racks or cabinets.

NOTICE!

When mounting the device into 19" equipment racks or cabinets, it is strongly recommended that you:

- **Always** fix the device at its **front AND rear rack ears** using appropriate rack mounting screws and U-washers, as shown in the graphic opposite.
 - Alternatively use shelves fixed to the inner sides of the equipment rack or cabinet.
-

Cooling

Thermal conditions are a vital factor to ensure operational safety of the power amplifiers. The amplifier is equipped with three internal fans that draw cool air from the front into the housing and channel the warm air towards the back of the device.

- Please ensure that adequate cool airflow is provided.
- Do not block or cover the front panel air intake or the vents on the rear panel.
- If the amplifiers are installed in sealed cabinets (e.g. in fixed installations), use additional fan modules with filters that can be easily replaced without opening the sealed cabinets.
- Do not combine the amplifiers with D6 or D12 amplifiers in one rack.
- Do not rack up the amplifiers together with other devices producing additional heat with opposing airflow.

5.2 Connections

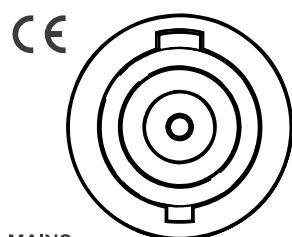
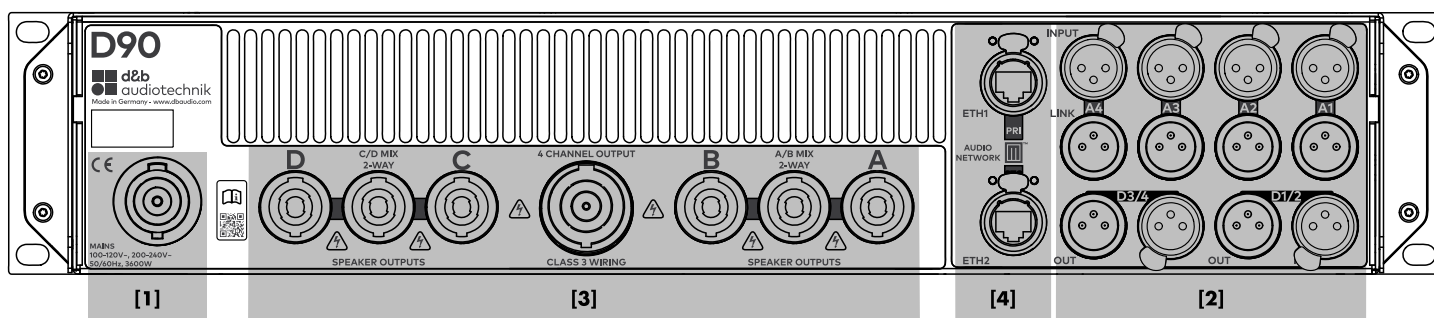

MAINS
100-120V~, 200-240V~
50/60Hz, 3600W

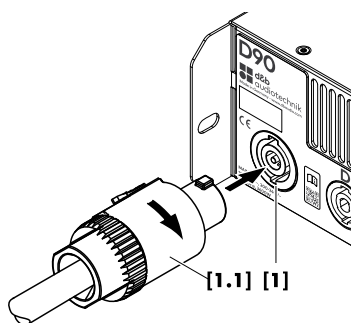

5.2.1 Mains connection



WARNING!

Potential risk of electric shock or fire.

The device is a protective class 1 unit. A missing earth (ground) contact may cause dangerous voltages in the housing and controls and may lead to electric shock.

- Connect the device to mains power supplies with protective earth only.
- If there is any sign of obvious damage to the power cord and/or mains plug, do not use the power cord and replace it before further use.
- Please ensure the mains connector is accessible at any time to disconnect the device in case of malfunction or danger. If the mains plug is not readily accessible due to mounting in a 19" rack or equipment cabinet, then the mains plug for the entire rack or cabinet must be readily accessible.
- Do not connect or disconnect the mains plug under load.

Required mains configuration

NOTICE!

Due to the high power capability of the device, only operate **one device per phase conductor**.

An appropriate circuit breaker from the on-site power distribution system is required:

- 100 - 127 VAC ~ 50/60 Hz - 30 A_{max}. B- or C-frame type.
- 208 - 240 VAC ~ 50/60 Hz - 16 A_{max}. B- or C-frame type.

Before connecting the device to mains voltage, check that the mains voltage and frequency correspond to the specifications on the rating label next to the mains connector socket on the rear panel of the unit.

A powerCON-HC® mains connector socket [1] is fitted on the rear panel and an appropriate power cord [1.1] is supplied.

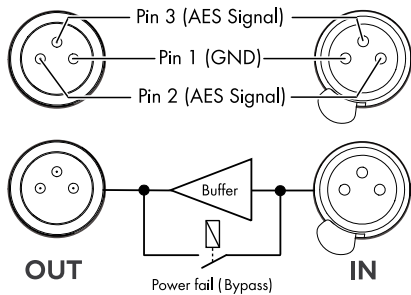
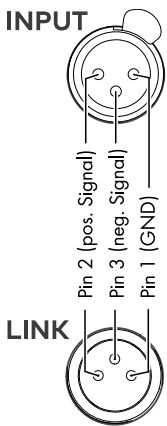
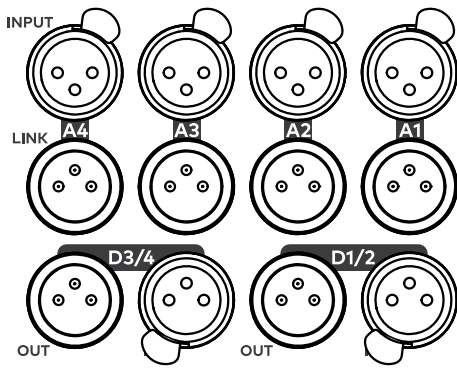

5.2.2 Audio INPUT and LINK/OUT connectors

The rear panel features eight audio input connectors with the following assignments:

- Four analog inputs (A1 - A4) with corresponding link outputs.
- Two digital AES3 inputs (D1/2 and D3/4 - four channels) with corresponding outputs.

The digital inputs are fitted with permanent, high-speed, high-quality SRCs, thus AES3 signals from different sources and with differing sample rates can be processed without requiring any further user configuration.

Each input channel can be routed to any of the output channels A to D.

Analog INPUT and LINK (A1 - A4)

A 3-pin female XLR input connector is provided for each channel. Wired in parallel is a 3-pin male XLR input link connector used to feed the input signal onto the next device in the signal chain.

Specifications

Pin assignment	1 = GND, 2 = pos., 3 = neg.
Input impedance	32 kOhms, electronically balanced
CMRR @ 100 Hz/1 kHz / 10 kHz	>80 / >80 / >70 dB
Maximum input level (balanced/unbalanced)	+25 / +18 dBu
.....	+27.3 dBu @ 0 dBFS
LINK (A1 - A4)	3 pin XLR male
.....	parallel to input

Digital input and output (IN/OUT - D1/2 - D3/4)

Two 3-pin female XLR digital input (IN) connectors (D1/2 and D3/4) are provided, each accepting a 2-channel AES (AES3) digital audio signal.

The corresponding 3-pin XLR male digital output (OUT) can be used to feed a refreshed input signal to the next device in the signal chain. The signal shape (the rising and falling edges of the signal) and level are refreshed using a latency free analog buffer amplifier.

A power fail relay is incorporated to prevent interruption of the signal chain should there be a power failure. In this situation, the digital input signal bypasses the analog buffer amplifier and is routed directly to the output (OUT).

Specifications

Pin assignment	1 = GND, 2 = AES Signal, 3 = AES Signal
Input impedance	110 ohms, transformer balanced
Sampling frequency	44.1 48 96 192 kHz
Word length	16 - 24 bit
OUT (D1/2 - D3/4)	3-pin XLR male
.....	electronically balanced
.....	analog signal buffering (refresh)
.....	Power Fail Relay (Bypass)

5.2.3 SPEAKER OUTPUTS

WARNING!
Potential risk of electric shock.

The amplifier output pins can carry dangerous voltages.

- Only use isolated loudspeaker cables with correctly fitted connectors.
- Never connect an amplifier output pin to any other input or output connector pin or protective earth (ground).

The amplifier is supplied with four NL4 output connectors (A/B - C/D) one for each amplifier output channel ⇒ Dual Channel configuration.

In addition, two NL4 connectors are provided, one for each pair of amplifier output channels to allow either Mix TOP/SUB (A/B MIX - C/D MIX) or 2-Way Active (2-WAY - 2-WAY) configurations.

All NL4 connector pins are hardwired and permanently driven using the following pin assignments:

SPEAKER OUTPUTS pin assignments

AMP	SPEAKER OUTPUTS					
	A	B	A/B	C	D	C/D
A	1+/1- 2+/2-		1+/1- 2+/2-			
B		1+/1- 2+/2-	2+/2-			
C				1+/1- 2+/2-		1+/1- 2+/2-
D					1+/1- 2+/2-	2+/2-

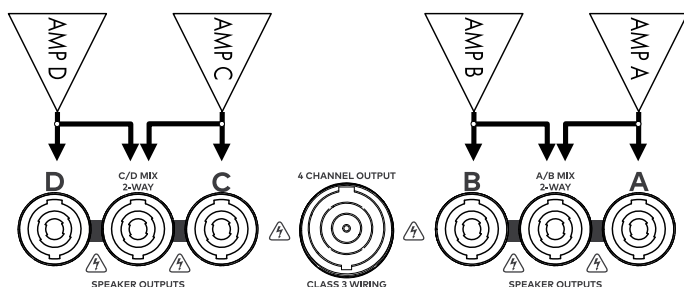

Output modes and connector assignments - exemplary

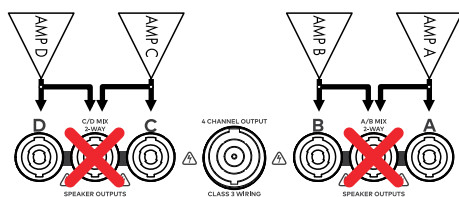

Dual Channel - Dual Channel
A/B - C/D

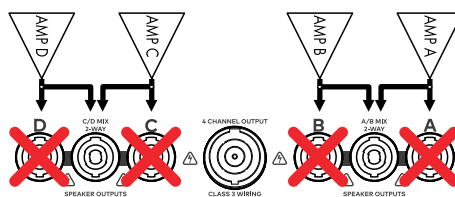

Mix TOP/SUB - Mix TOP/SUB
A/B MIX - C/D MIX

Or...
2-Way Active - 2-Way Active
2-WAY - 2-WAY

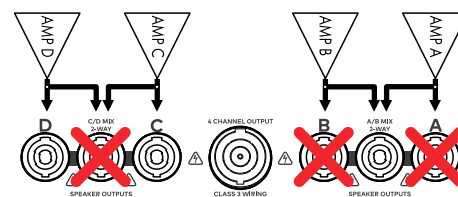

Mix TOP/SUB - Dual Channel
A/B MIX - C/D

Or...
2-Way Active - Dual Channel
2-WAY - C/D

Note: For further information regarding the applicable output modes for each loudspeaker system, please refer to the relevant loudspeaker manual.

4 CHANNEL OUTPUT

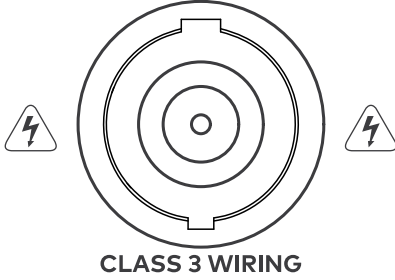

4 CHANNEL OUTPUT

NOTICE!

The 4 CHANNEL OUTPUT connector is only intended as an interface to a rack panel or to loudspeaker multicores and breakout adapters.

Do not connect any loudspeaker cabinet, neither passive nor active systems, to this connector, otherwise there is a risk of damaging the loudspeaker components or the amplifier.

The centered NL8 connector carries the output signals of all four amplifier channels with the following pin assignment:

1+/- = Channel A pos. / neg.	2+/- = Channel B pos. / neg.
3+/- = Channel C pos. / neg.	4+/- = Channel D pos. / neg.

5.2.4 Network connections

NOTICE!

Only **shielded network** cables (**STP**) must be used!

The device allows remote control as well as redundant digital audio networking (Milan™) via Ethernet.

For this purpose, a Dual Ethernet port (1 Gbit/s/100 Mbit/s – peer-to-peer) is provided requiring star topology network wiring. Daisy-chaining is not supported.

For standard remote control via the d&b Remote network using the d&b R1 Remote control software or the integrated Web remote interface, **the upper etherCON® (ETH1/PRI)** connector socket is used.

This connector socket is also used for the primary (**PRI**) Milan™ signal while the bottom etherCON® connector socket (**ETH2/SEC**) is used for the redundant Milan™ signal only.

LED indicators

The two LED indicators above the respective connector in use indicate the following states:

- Green** ● Illuminates permanently when the device is connected to an active network and flashes as long as a data stream is transmitted.
- Yellow** ●
 - Is off when the speed is 100 Mbit/s.
 - Illuminates permanently when the speed is 1 Gbit/s.

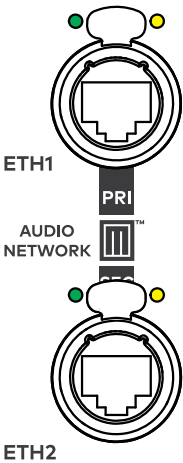

Milan secondary
ETH2/SEC

Gbit Ethernet (star topology)

ETH1/PRI
Milan primary
Remote (R1)

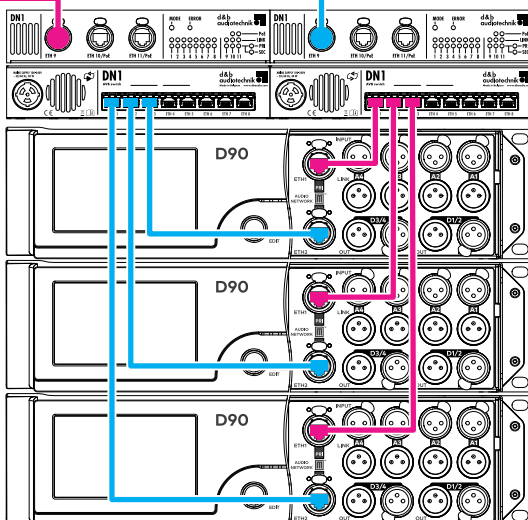

5.3 Controls and indicators

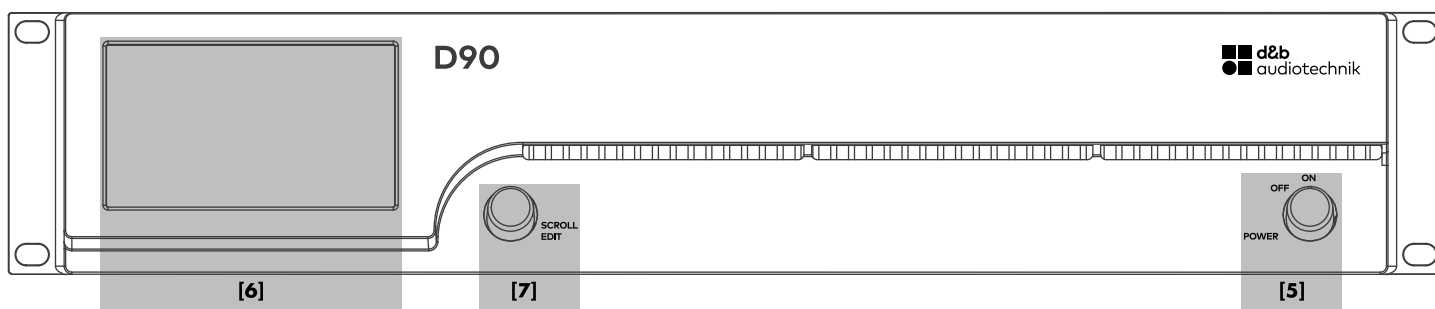

5.3.1 Mains power switch

The on/off rotary switch [5] is located on the bottom right of the front panel.

- OFF** Mains isolation is not provided. The internal power supplies are off but remain connected to the mains.
- ON** The unit is switched on and ready for operation.

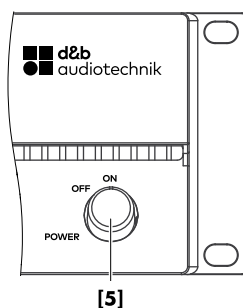

5.3.2 TFT color touchscreen - User interface

NOTICE!

The touch panel utilizes a thin flexible sheet that may be damaged by sharp objects or heavy treatment.

The user interface consists of a 4.3" TFT color touchscreen [6] with a resolution of 480 x 272 pixels and an additional digital rotary encoder [7].

The resistive touchscreen responds to pressure and therefore can be operated by a fingertip, even when wearing gloves or by an appropriate stylus tip (pen).

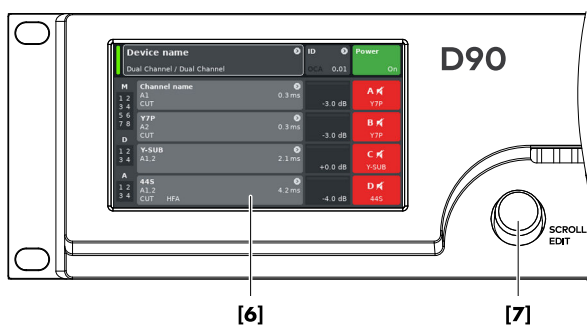

Device name		ID	Power
Dual Channel / Dual Channel		OCA 0.01	On
M	Channel name		
1 2	A1	0.3 ms	A
3 4	CUT	-3.0 dB	Y7P
5 6	Y7P		B
7 8	A2	0.3 ms	Y7P
D	CUT	-3.0 dB	
1 2	Y-SUB		C
3 4	A1,2	2.1 ms	Y-SUB
		+0.0 dB	
A	44S		D
1 2	A1,2	4.2 ms	
3 4	CUT HFA	-4.0 dB	44S

5.3.2.1 Operating concept

Home screen

From the Home screen, the menu structure of the operating software is divided into two main axes, the «Device» setup and the «Channel» setup.

The navigation buttons allow for direct vertical access to the specific submenus while the tab structure on the right side of each submenu provides a clear horizontal order.

In addition, the Home screen gives direct access to the Network subscreen.

The Home screen can be accessed from any screen or menu at any level using the Home button (🏠).

Home screen access chart

Hierarchy level

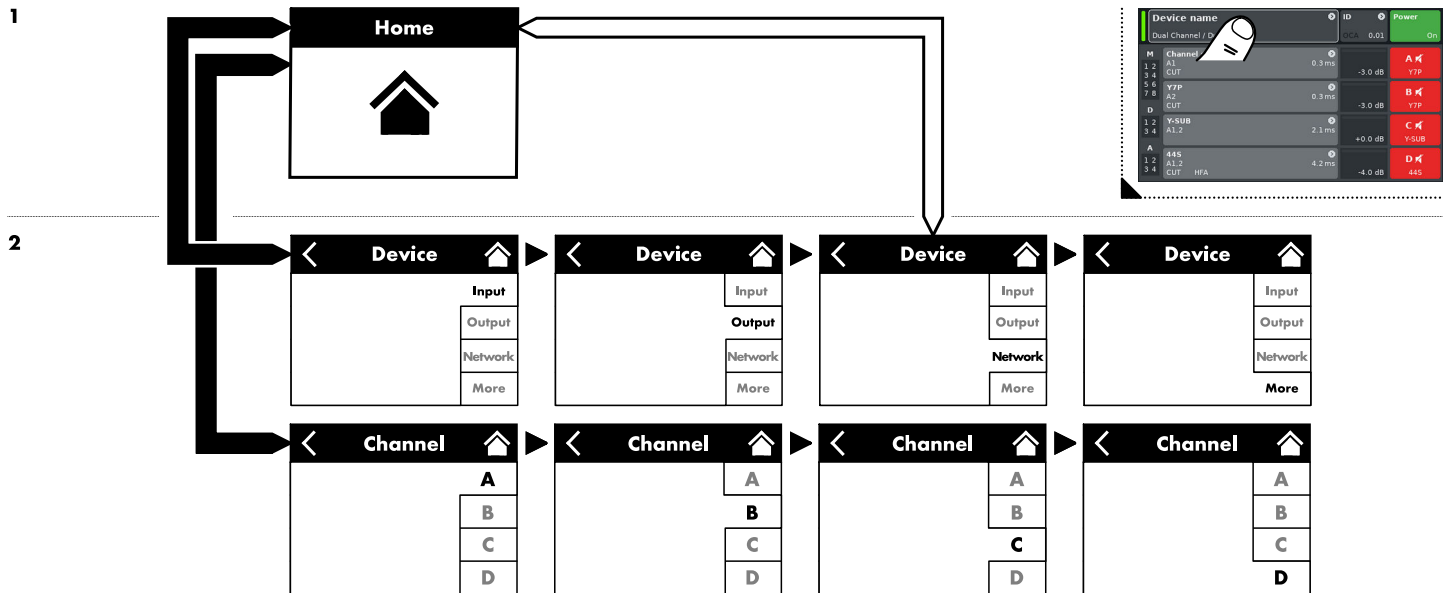

A detailed description of the «Device» and «Channel» setup menu structure and screen contents is given in the D90 Reference manual (in English language), which can be downloaded from the related product page at www.dbaudio.com.

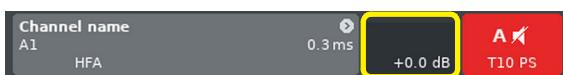
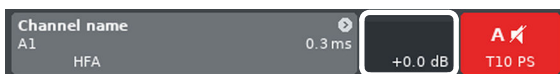

Cursor conventions

The graphical user interface features two types of cursors, the «Position» and the «Edit» cursors.

Position cursor



The Position cursor marks the selected menu item by a white frame. Depending on the type of screen item, the Position cursor allows you to either activate a function, navigate through the menu or enter Edit mode ⇒ Edit cursor.

Edit cursor

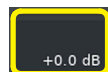

In Edit mode, the Edit cursor is marked by a yellow frame. Turning the encoder to the right (clockwise) increases the current value, turning the encoder to the left (counterclockwise) decreases it.

To leave Edit mode press the encoder or simply select the respective menu item again. The color of the frame will change from yellow back to white again ⇒ Position cursor.

Interaction

The operating concept allows different methods of interaction and configuration.

Touchscreen in combination with the rotary encoder

This method may preferably be used to set values of input fields such as Gain settings, CPL, Delay or EQ settings.

- Select menus, menu items and/or function elements by selecting the relevant item.
- Enter/edit values by turning the encoder.
- Confirm entered/changed values by selecting the respective item again or the confirmation button («OK») or pushing the encoder.

Rotary encoder only

This method is mainly intended for users who are familiar with the user interfaces of other d&b amplifiers.

- Select menus, menu items and/or function elements by turning the encoder to move the Position cursor to the relevant item.
- Access the selected item or function element by pushing the encoder.
- Enter/edit values by turning the encoder.
- Confirm entered/changed values or leave Edit mode by pushing the encoder.

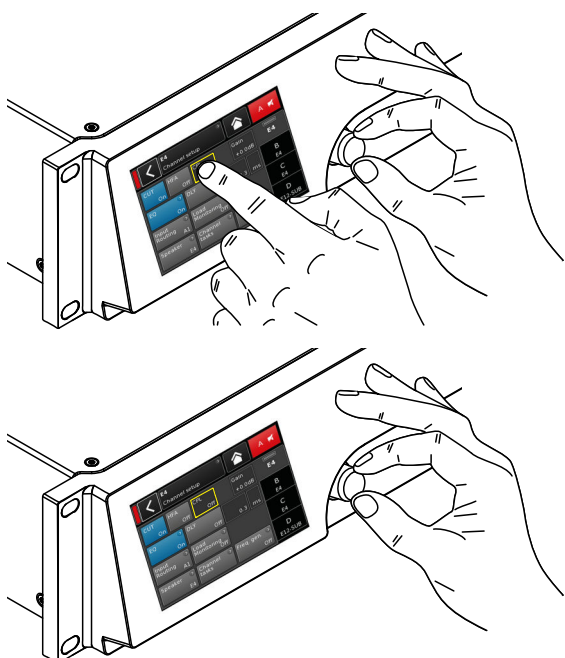



5.3.2.2 Standby mode

To switch the device to Standby mode, proceed as follows:

1. Select the «Power» button on the top right of the home screen.
 - ↳ A dialog appears allowing you to either select the Back button (⌫ - Cancel), «Mute all» or «Standby».
2. Select «Standby».

↳ When the device is in Standby mode, both the green power indicator on the left and the «Power» button on the right are switched off. In addition, on the «Device view» button, Standby flashes alternating with the Device name.

The operating state (Standby mode) is stored when the «Power» button is set to "Off" and will be restored when the «Power» button is set back to "On" again.

In Standby mode, the main power supply and the power amplifiers are switched off to save energy.

All level indicators/metering controls remain functional.

The display and controls (User interface) remain active to allow repowering of the device by remote control or by selecting the «Power» button on the Home screen.

3. To repower the device, select the «Power» button again.
 - ↳ During the transition from Standby to "On", the power indicator on the left and the «Power» button on the right illuminates orange and will switch to green as soon as the device is repowered.

Notes on Standby

When the device is set to Standby (or the mains power is switched off), the movement of the loudspeaker cones in the connected cabinets is no longer damped by the power amplifier output. This removal of the damping makes them susceptible to excitation by other loudspeakers in the surroundings. Audible resonances may occur, and even absorption of low frequency sound energy as the undamped loudspeakers act like a "bass trap".

To permanently mute single subwoofer cabinets while others are operated at the same time it is therefore preferable to use the Mute function instead of Standby. However, the Standby mode can be useful with mid/high systems as it removes any residual noise from the system.

5.3.2.3 Mute functions

The device provides two mute functions:

- Individual mute buttons for each channel or pair of channels, depending on the output mode configuration:
 - ⇒ Channel mute,
- Master mute function:
 - ⇒ «Mute all».

Note: The device stores the setting of the mute buttons when the mains power is switched off or disconnected. When the unit is switched on or reconnected, the mute status will be recalled.

Channel mute

⇒ To mute or unmute a channel or a pair of channels, simply select the respective Channel mute button.

- ↳ The Channel mute button displays the mute status of the relevant channel or pair of channels and the loudspeaker setup loaded.



Channel muted



Channel unmuted

Master mute («Mute all»)

1. To mute all channels simultaneously, select the «Power» button on the top right of the Home screen.
 - ↳ A dialog appears allowing you to either select the Back button (⌫ - cancel), «Mute all» or «Standby».
2. Select «Mute all».
3. To unmute the channels, use the individual Channel mute buttons.

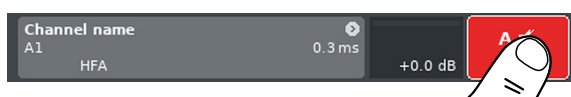

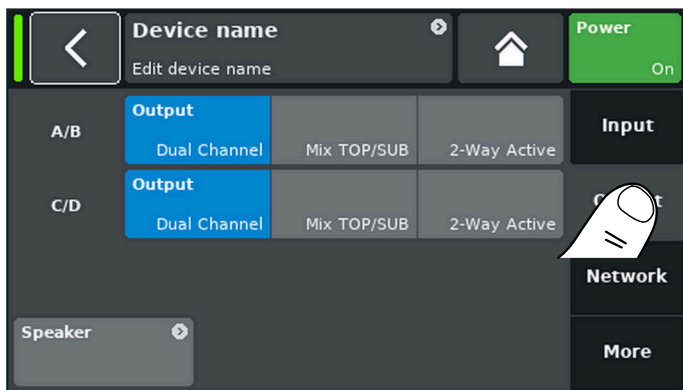
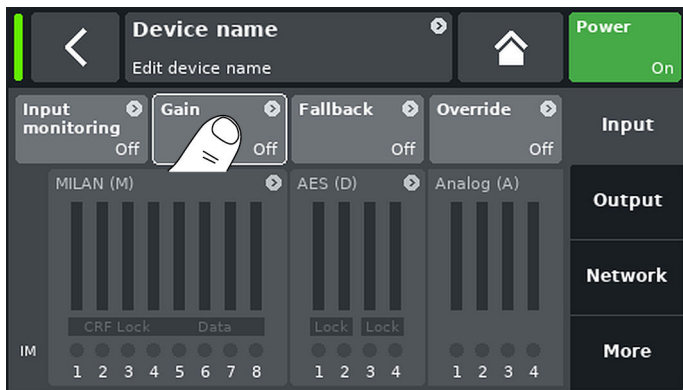
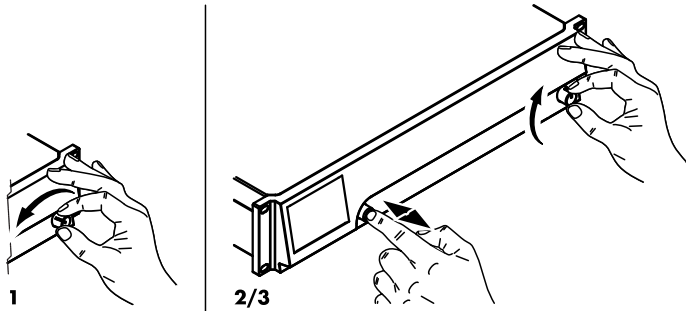

Due to the vast functional range and possible settings of the device, this section is intended as a quick reference to provide you with a systematic procedure for defining the basic settings of the device.

It is advisable to start with the device settings followed by the individual channel settings.

1. System reset

Before starting to define the basic settings, perform a system reset. For this purpose, proceed as follows:

1. Switch off the device.
2. Press and hold the encoder and repower the device.
 - ↳ Long confirmation beep.
3. Release the encoder and briefly press the encoder again within 2 sec.
 - ↳ Short confirmation beep.
 - The device will boot up and will switch to the Home screen. A corresponding message will be issued:

All device settings have been cleared

2. Device setup

- ⇒ On the Home screen, select the Device view button.
 - ↳ This will enter the Device setup subscreen with the «Input» tab being active.

3. Input

- ⇒ Define your desired input settings for all channels correspondingly.
 - ↳ In addition you can also set the input gain of the individual input, ranging from -57.5 to +6 dB.

Input gain	M1	M2	M3	M4	Mon
On	-140.0 dBFS +0.0 dB	-140.0 dBFS +0.0 dB	-140.0 dBFS +0.0 dB	-140.0 dBFS +0.0 dB	
Clear	M5	M6	M7	M8	Gain
	-140.0 dBFS +0.0 dB	-140.0 dBFS +0.0 dB	-140.0 dBFS +0.0 dB	-140.0 dBFS +0.0 dB	
	D1	D2	D3	D4	Fallback
	-140.0 dBFS +0.0 dB	-140.0 dBFS +0.0 dB	-140.0 dBFS +0.0 dB	-140.0 dBFS +0.0 dB	
	A1	A2	A3	A4	Override
	-97.8 dBu +0.0 dB	-97.4 dBu +0.0 dB	-97.6 dBu +0.0 dB	-97.5 dBu +0.0 dB	

Shiftable input gain

4. Output (Output mode)

- ⇒ Select the «Output» tab and define your desired output mode settings for each pair of amplifier channels correspondingly.

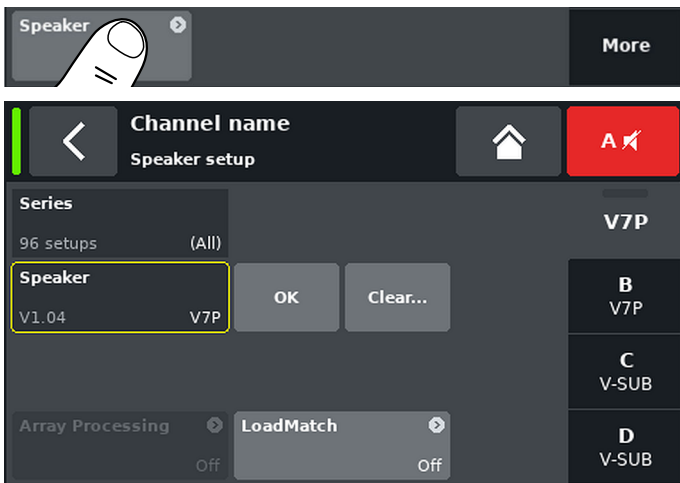

5. Speaker

1. On the bottom left of the «Output» tab, select the «Speaker» navigation button to enter the Speaker setup subscreen.
2. Choose the desired speaker setups for all channels and confirm each selected setup by selecting the «OK» button right next to the «Speaker» selection field.
3. Define the «LoadMatch» settings, if applicable and desired, correspondingly.
4. After defining all settings, exit the subscreen by selecting the Home button (🏠).

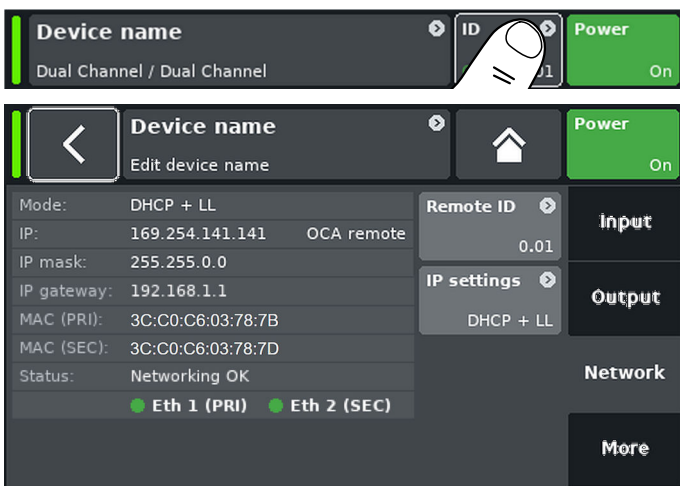

6. Network

1. On the Home screen, select the «ID» button to enter the Network setup menu.
2. Define your desired Network settings correspondingly.
 - ↳ **Note:** As all the configurations and settings mentioned above can also be defined remotely, it depends on how you wish to proceed whether defining the Network settings is the last or the first step when configuring your basic settings.
3. After defining all settings, exit the subscreen by selecting the Home button (🏠) and carry on with the individual channel settings.

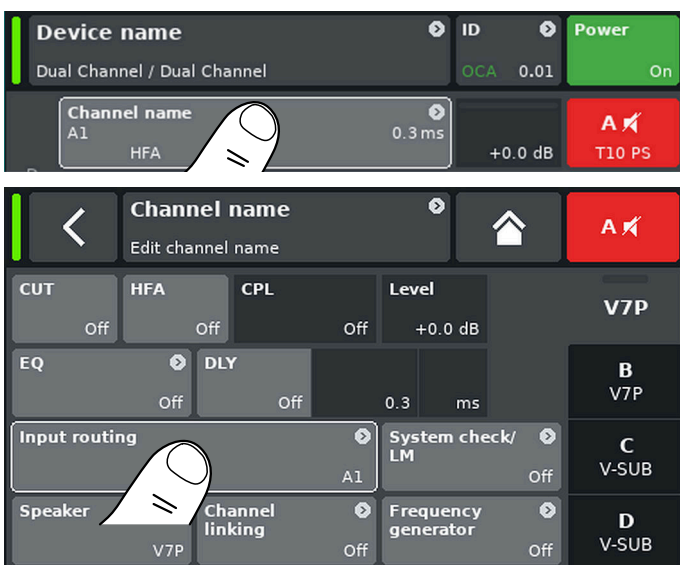

7. Channel setup

1. On the Home screen, select the Channel view button of the first channel (A) or pair of channels (A/B) to enter the Channel setup.
2. Define your individual channel settings such as CUT, HFA, CPL, Level, DLY or EQ as well as the input routing for all channels correspondingly.

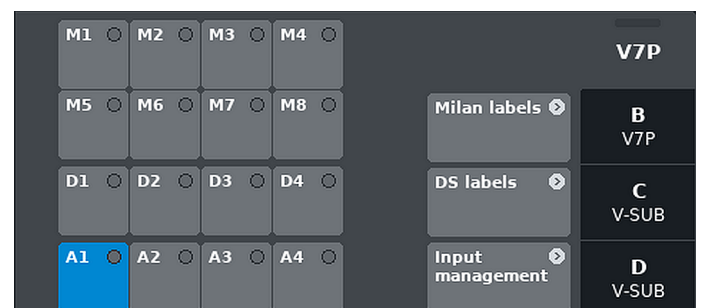

Input routing

3. After defining all settings, exit the subscreen by selecting the Home button (🏠).

7.1 Service



CAUTION!
Potential risk of explosion.

The device incorporates a lithium battery which may cause danger of explosion if not replaced correctly.

Refer replacement only to qualified service personnel authorized by d&b audiotechnik.

Do not open the device. No user serviceable parts inside. In case of any damage do not operate the device under any circumstances.

Refer servicing only to qualified service personnel authorized by d&b audiotechnik. In particular if:

- objects or liquids have entered the device.
- the device does not operate normally.
- the device was dropped or the housing is damaged.

7.2 Maintenance and care

During normal operation, the amplifier provides maintenance-free service.

Due to the cooling concept, no dust filters are required. As a result, filter exchange or cleaning the filters is not necessary.

7.2.1 Touchscreen cleaning

After a certain period of time, the touchscreen may require cleaning.

For this purpose, proceed as follows:

- Use a soft cloth only.
- Do not use any solvent cleaners.

To remove very heavy dirt from the panel, it may be helpful to use a special cleaning spray for TFT screens. In this case, proceed as follows:

1. Spray on the soft cloth before wiping the screen.
 - ↳ Never apply/spray directly on the screen as the liquid could penetrate the device.
2. Wipe the screen with moderate pressure.

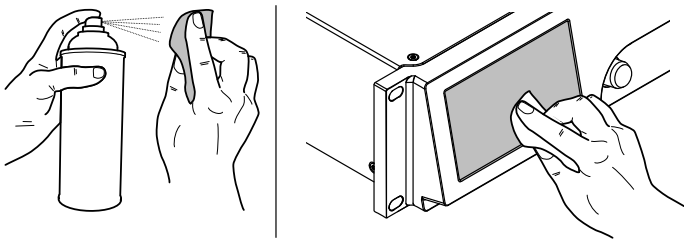

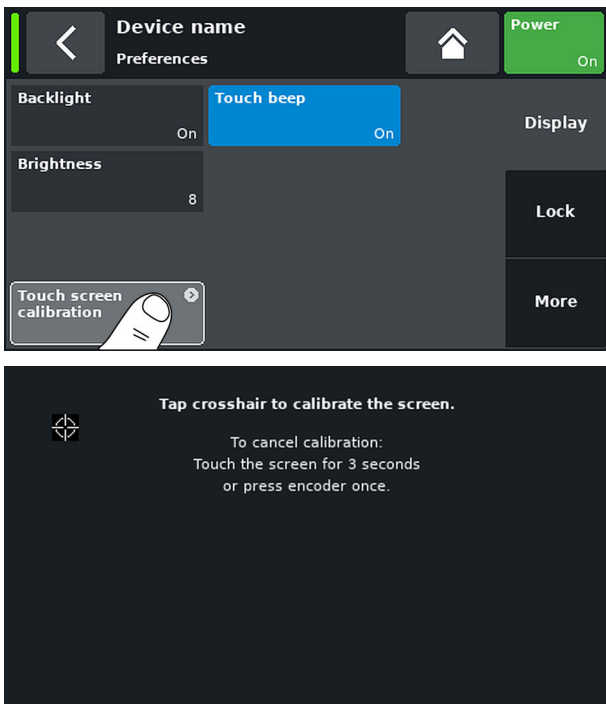

7.2.2 Touchscreen calibration

Indication

Due to mechanical impact or the aging process of the touchscreen, its calibration references may change.

An indication is that when you tap a specific button and the adjacent button is activated instead or when a specific button does no longer work.

In such cases, the touchscreen should be recalibrated.

Calibration

To calibrate the touch screen, proceed as follows:

1. From the «Home» screen go to «Device» ⇒ «More» ⇒ «Preferences» ⇒ «Display».
2. On the bottom left, select «Touch screen calibration».
 - ↳ The calibration menu will be issued, guiding you through the calibration procedure.
3. Follow the on-screen instructions respectively.



8.1 Declaration of Conformity

This declaration applies to:

d&b Z2860 D90 Amplifier

by d&b audiotechnik GmbH & Co. KG.

All product variants are included, provided they correspond to the original technical version and have not been subject to any later design or electromechanical modifications.

We herewith declare that said products are in conformity with the provisions of the respective directives including all applicable amendments.

Detailed and applicable declarations are available on request and can be ordered from d&b or downloaded from the d&b website at www.dbaudio.com.



8.2 WEEE Declaration (Disposal)

Electrical and electronic equipment must be disposed of separately from normal waste at the end of its operational lifetime.

Please dispose of this product according to the respective national regulations or contractual agreements. If there are any further questions concerning the disposal of this product, please contact d&b audiotechnik.

WEEE-Reg. -Nr. DE: 13421928

8.3 Licenses and Copyright

A list of the components and a full-text version of all licenses and copyrights can be accessed using the amplifier's Web Remote interface.

⇒ Selecting the d&b logo at the top left of the «Web Remote» interface page allows access to the «Licenses and Copyright» information page.

This page provides an overview of the open source software used in this product. As required by the GPL and LGPL licenses, we will send you a copy of the used source code on request. If you would like to obtain a copy, please contact us by mail to: software.support@dbaudio.com

