

# J

**J8/J12**  
**Manual 2.2 en**

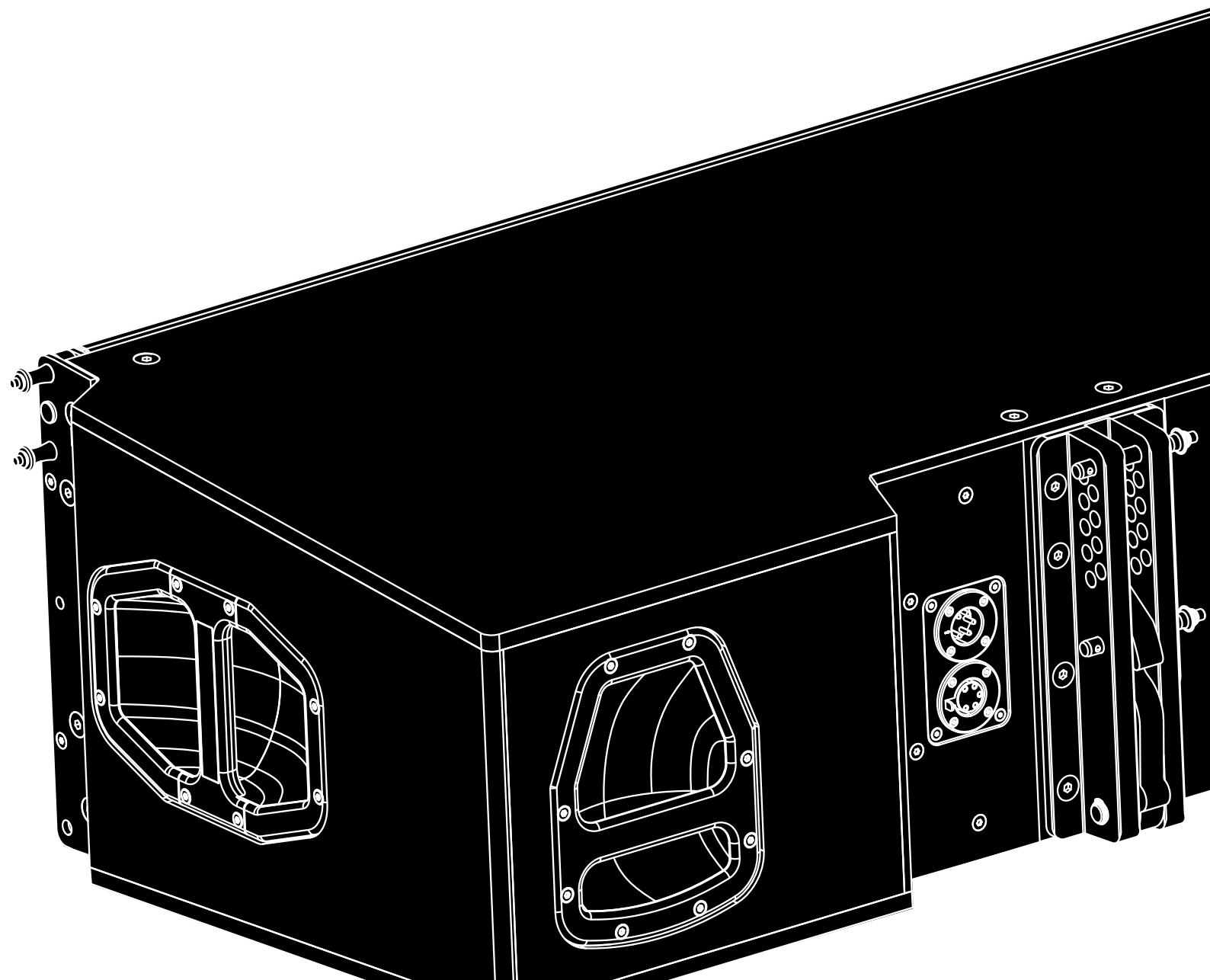

## **General information**

J8/J12 Manual

Version: 2.2 en, 03/2016, D2980.EN .02

Copyright © 2016 by d&b audiotechnik GmbH; all rights reserved.

**Keep this manual with the product or in a safe place so that it is available for future reference.**

When reselling this product, hand over this manual to the new owner.

If you supply d&b products, please draw the attention of your customers to this manual. Enclose the relevant manuals with the systems. If you require additional manuals for this purpose, you can order them from d&b.

d&b audiotechnik GmbH  
Eugen-Adolff-Strasse 134, D-71522 Backnang, Germany  
T +49-7191-9669-0, F +49-7191-95 00 00  
docadmin@dbaudio.com, www.dbaudio.com

<b>1. Safety precautions</b> .....	<b>4</b>
1.1. Information regarding the use of loudspeakers.....	4
<b>2. J8/J12 loudspeaker</b> .....	<b>5</b>
2.1. Product description.....	5
2.2. Connections.....	6
2.3. Operation.....	6
2.3.1. Controller settings.....	7
2.4. Dispersion characteristics.....	8
2.5. Technical specifications.....	9
<b>3. Manufacturer's declarations</b> .....	<b>10</b>
3.1. EU conformity of loudspeakers (CE symbol).....	10
3.1.1. WEEE Declaration (Disposal).....	10

## 1.1. Information regarding the use of loudspeakers

### Potential risk of personal injury

Never stand in the immediate vicinity of loudspeakers driven at a high level. Professional loudspeaker systems are capable of causing a sound pressure level detrimental to human health. Seemingly non-critical sound levels (from approx. 95 dB SPL) can cause hearing damage if people are exposed to it over a long period.

In order to prevent accidents when deploying loudspeakers on the ground or when flown, please take note of the following:

- When setting up the loudspeakers or loudspeaker stands, make sure they are standing on a firm surface. If you place several systems on top of one another, use straps to secure them against movement.
- Only use accessories which have been tested and approved by d&b for assembly and mobile deployment. Pay attention to the correct application and maximum load capacity of the accessories as detailed in our specific "Mounting instructions" or in our "Flying system and Rigging manuals".
- Ensure that all additional hardware, fixings and fasteners used for installation or mobile deployment are of an appropriate size and load safety factor. Pay attention to the manufacturers' instructions and to the relevant safety guidelines.
- Regularly check the loudspeaker housings and accessories for visible signs of wear and tear, and replace them when necessary.
- Regularly check all load bearing bolts in the mounting devices.

### Potential risk of material damage

Loudspeakers produce a static magnetic field even if they are not connected or are not in use. Therefore make sure when erecting and transporting loudspeakers that they are nowhere near equipment and objects which may be impaired or damaged by an external magnetic field. Generally speaking, a distance of 0.5 m (1.5 ft) from magnetic data carriers (floppy disks, audio and video tapes, bank cards, etc.) is sufficient; a distance of more than 1 m (3 ft) may be necessary with computer and video monitors.

## 2. J8/J12 loudspeaker

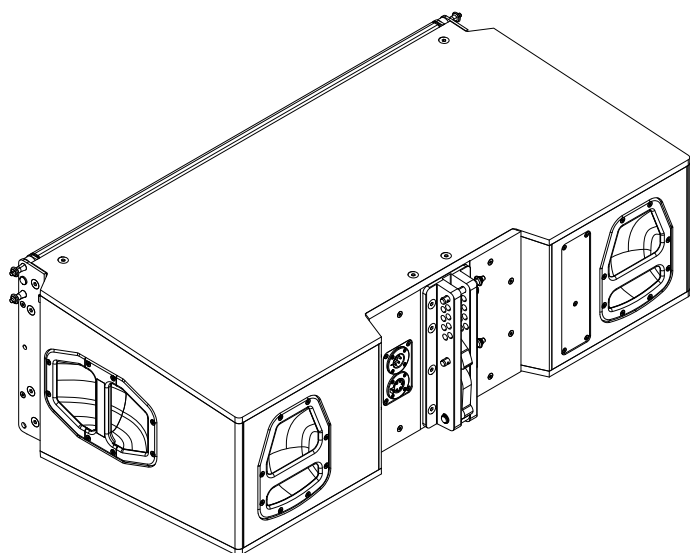
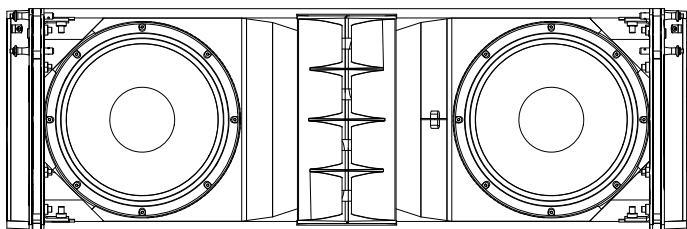

### 2.1. Product description

The J8 is a line array loudspeaker for large-scale sound reinforcement. When the J Flying Frame is used, J8 cabinets can be flown in vertical columns with up to 24 cabinets producing a 80° constant directivity dispersion pattern in the horizontal plane.

The J12 line array module is acoustically and mechanically compatible with the J8 and provides a 120° horizontal dispersion.

The J8 cabinet is a 3-way design housing 2 x 12" neodymium LF drivers, one horn-loaded 10" MF driver and 2 x 1.4" exit HF compression drivers with 3" coils mounted to a dedicated wave shaping device. The cylindrical wave segments of each cabinet couple without gaps and sum up coherently. Splay angles between adjacent cabinets can be set in the range from 0° to 7° in 1° increments.

J cabinets are driven by two channels of the respective d&b amplifier providing the active crossover between LF and mid/high section. MF and HF drivers are crossed over passively within the cabinet.

All components are arranged symmetrically around the center axis of the cabinet to produce a perfect symmetrical dispersion pattern. This set up allows for a very smooth crossover design with a well defined overlap of adjacent frequency bands resulting in a very consistent and accurate horizontal dispersion. Due to the dipolar arrangement of the LF drivers the nominal dispersion of 80° is maintained down to 300 Hz for J8 cabinets (120° down to 200 Hz for J12 cabinets).

The frequency response extends from 48 Hz to above 17 kHz.

The cabinets are constructed from marine plywood and have an impact and weather protected PCP (Polyurea Cabinet Protection) finish. The fronts of the cabinets are protected by a rigid metal grill backed by an acoustically transparent foam. Each side panel incorporates a handle while two additional handles are provided at the rear.

### J-Series rigging components and arrays

Cabinets are mechanically connected using the rigging strands at both sides of the cabinet front and a central strand at the rear of the cabinet which also serves as a heat sink for the MF driver. All necessary rigging components are mounted to the cabinet and fold or slid out when needed.

A detailed description of the J-Series rigging components is given in the J-Series Rigging manual which is provided with the J Flying frame.

A detailed description of planning and designing J arrays is given in the technical information "TI 385 d&b Line array design, d&b ArrayCalc" which is also provided with the J Flying frame.

The d&b ArrayCalc simulation software can be downloaded from the d&b website at [www.dbaudio.com](http://www.dbaudio.com).

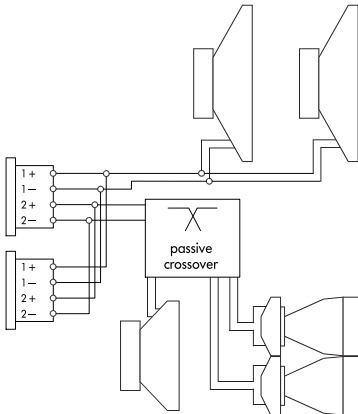

**NLT4 F/M Connector wiring**

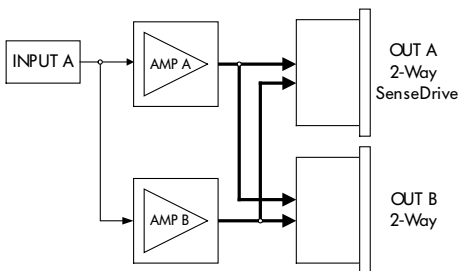

**D12 Input/Output routing 2-Way Active mode**

## 2.2. Connections

The cabinets are fitted with NLT4 F/M connectors. All four pins of both connectors are wired in parallel. The cabinet uses the pin assignments 1+/1- for the LF drivers. Pins 2+/2- are designated to MF/HF section. Using one connector as the input, the second connector allows for direct connection to a second cabinet.

The cabinets can be supplied with EP5 or NL8 connectors as an option.

Pin equivalents of the connector options are listed in the table below.

	LF +	LF -	HF/ MF +	HF/ MF -	SenseDrive (SD)
<b>NLT4 F/M</b>	1+	1-	2+	2-	n.a.
<b>EP5</b>	1	2	3	4	5
<b>NL8</b>	1+	1-	4+	4-	3-

## d&b LoadMatch

Starting with the D80 amplifier platform, the LoadMatch function enables the amplifier to electrically compensate for the properties of the loudspeaker cable used without the need for an additional sense wire. For applicable loudspeakers, LoadMatch is therefore independent of the connector type used.

## d&b SenseDrive

The SenseDrive feature within D12 amplifiers enables electrical compensation for the properties of the loudspeaker cable used. SenseDrive requires an additional sense wire. SenseDrive is therefore only available with EP5 connectors and 5-wire cabling for applicable loudspeakers.

**Note:** To enable SenseDrive, at least one of the cabinets has to be connected to output A of the D12 amplifier.

## 2.3. Operation

### NOTICE!

Only operate d&b loudspeakers with a correctly configured d&b amplifier, otherwise there is a risk of damaging the loudspeaker components.

### Applicable d&b amplifiers:

D80/D12/30D.

Application	Setup	Cabinets per pair of amplifier channels
<b>J8</b>	J8 Arc/J8 Line	2
<b>J12</b>	J12 Arc/J12 Line	2

The applicable amplifiers provide two setups ("Arc" or "Line") for the J8 and J12 loudspeakers. These are available in 2-Way Active mode.

### Arc and Line setups

The selection of Arc or Line depends on the curvature of the array. Both setups may be used within one array.

The Arc setup is intended for line array loudspeakers when used in curved array sections.

The Line setup is used for long throw array sections with three or more consecutive splay settings of 0° or 1°. Compared to the Arc setup, the mid/high range is reduced to compensate for the extended nearfield.

The transition from Line to Arc configuration within the array is made according to the splay progression but may allow for certain deviations due to the wiring of the cabinets in groups of up to two.

### 2.3.1. Controller settings

For acoustic adjustment the functions CUT, CPL and HFC can be selected.

#### CUT mode

Set to CUT, the low frequency level of the cabinets is reduced. The J8/J12 array is now configured for use with the d&b J-SUB or subwoofers.

#### CPL function

The CPL (Coupling) circuit compensates for coupling effects between the cabinets by reducing the low and mid frequency level. The CPL function should be selected when J8/J12 cabinets are used in arrays of five or more.

As coupling effects increase with the length of the line array, the CPL circuit can be set to dB attenuation values between 0 and -9. CPL begins gradually at 2 kHz, with the maximum attenuation below 100 Hz. With higher attenuation values the corner frequency of the filter shifts towards lower values.

**Note:** The CPL function is shown in the diagram opposite. Please note that all cabinets within the line array should be operated with the same CPL setting.

#### HFC function

Selecting the HFC (High Frequency Compensation) function compensates for the loss of high frequency energy due to air absorption when loudspeakers are used to cover far field listening positions.

The HFC function has two settings (HFC1 and HFC2) for different distances the cabinets need to cover. The settings should be used selectively; HFC1 for cabinets covering distances larger than 40 m (130 ft) and HFC2 for those covering distances larger than 80 m (260 ft).

The compensation is adjusted for a typical relative humidity of 40%. With lower humidity the absorption by air increases therefore the distances where the respective HFC setting provides a correct equalization are shorter than indicated above.

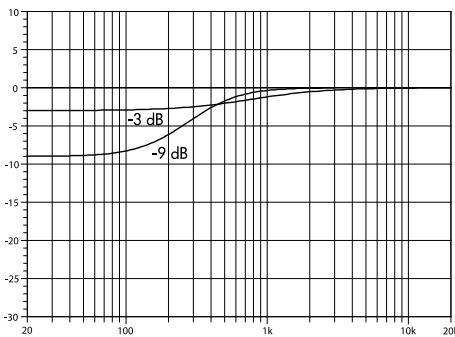

Frequency response correction of the CPL function

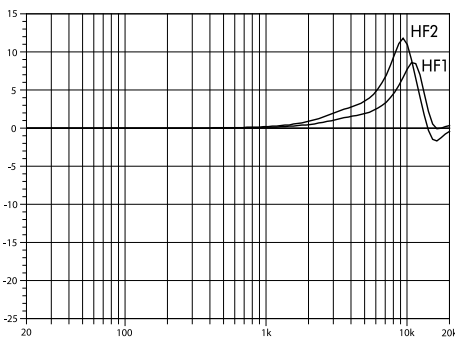

Frequency response correction of the HFC function

Using the HFC function provides the correct sound balance between close and remote audience areas, whilst all amplifiers driving the array can be fed with the same signal.

#### 2.4. Dispersion characteristics

The graphs below show the horizontal dispersion angle over frequency plotted using lines of equal sound pressure (isobars) at -6 dB and -12 dB. The nominal dispersion is maintained above 300 Hz (J8)/200 Hz (J12).

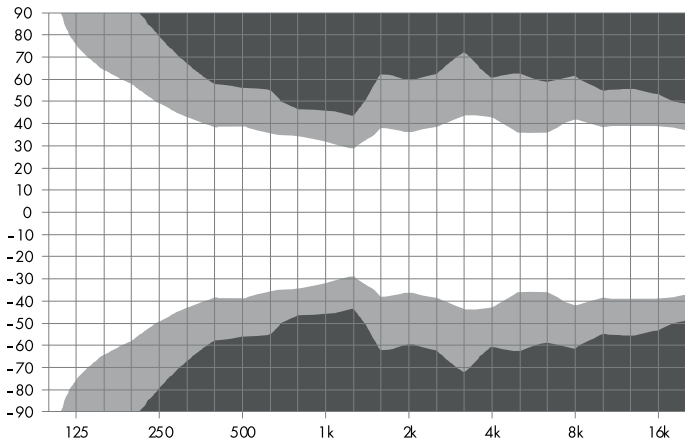

Isobar diagram J8 horizontal

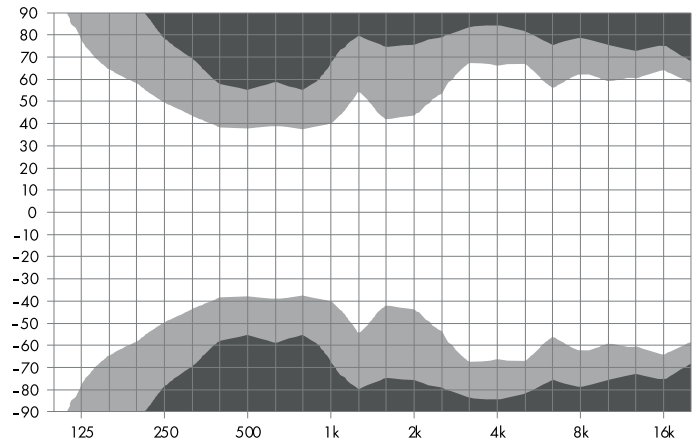

Isobar diagram J12 horizontal



## 2.5. Technical specifications

### J8/J12 system data

Frequency response (-5 dB standard)	48 Hz - 17 kHz
Frequency response (-5 dB CUT mode)	85 Hz - 17 kHz
Max. sound pressure (1 m, free field)	
J8 with D80/D12/30D	145 dB
J12 with D80/D12/30D	143 dB
	(SPLmax peak, pink noise test signal with crest factor of 4)

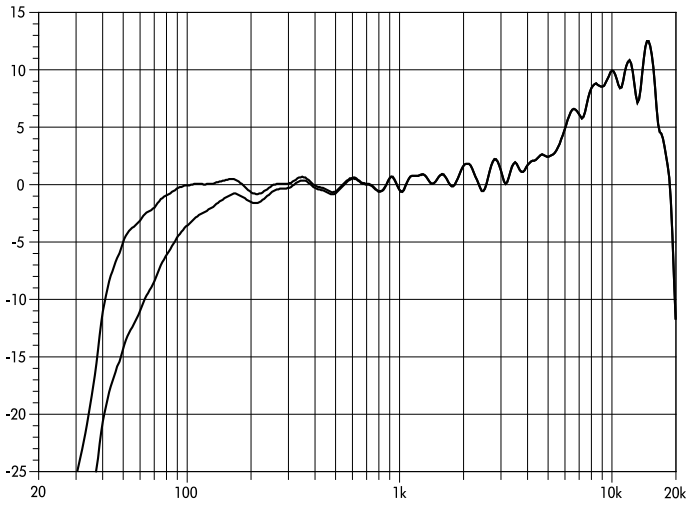

J8 frequency response, standard and CUT modes

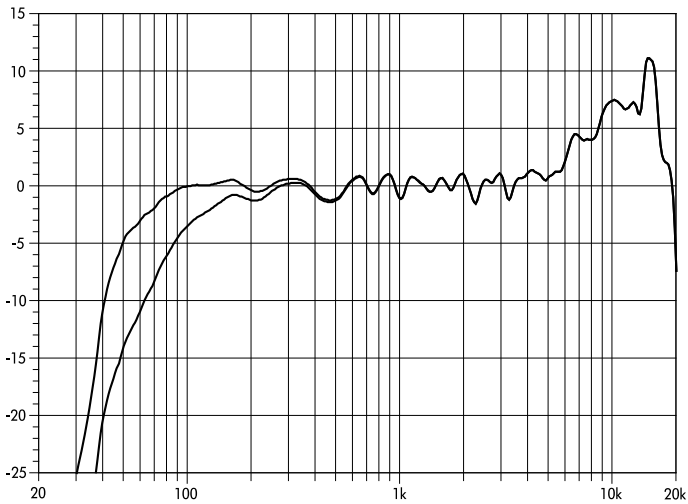

J12 frequency response, standard and CUT modes

### J8/J12 loudspeaker

Nominal impedance LF/MHF	6/12 ohms
Power handling capacity LF (RMS/peak 10 ms)	500/2000 W
Power handling capacity MHF (RMS/peak 10 ms)	200/800 W
Nominal dispersion angle (horizontal) J8/J12	80/120°
Splay angle setting	0 ... 7 (1° increment)°
Components	2 x 12" LF driver
	1 x 10" MF driver
	2 x 1.4" exit compression driver
	Passive crossover network
Connections	2 x NLT4 F/M
	optional 2 x EP5 or NL8
Pin assignment	NLT4 F/M: 1+: LF+/1 -: LF- / 2+: MHF+/2 -: MHF-
	EP5: 1: LF+ / 2: LF- / 3: MHF+ / 4: MHF- / 5: SD
	NL8: 1+: LF+ / 1 -: LF- / 4+: MHF+ / 4 -: MHF- / 3 -: SD
Weight	60 kg (132 lb)

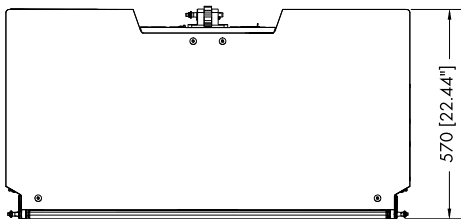
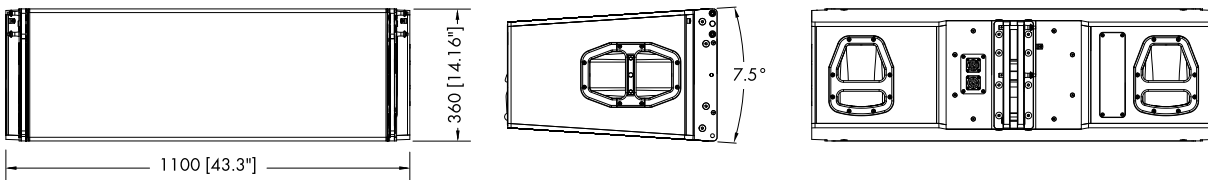

J8/J12 cabinet dimensions in mm [inch]



### 3.1. EU conformity of loudspeakers (CE symbol)

This declaration applies to:

**d&b J8 loudspeaker, Z0650**

**d&b J12 loudspeaker, Z0651**

manufactured by d&b audiotechnik GmbH.

All production versions of these types are included, provided they correspond to the original technical version and have not been subject to any later design or electromechanical modifications.

We herewith declare that said products are in conformity with the provisions of the respective EC directives including all applicable amendments.

A detailed declaration is available on request and can be ordered from d&b or downloaded from the d&b website at [www.dbaudio.com](http://www.dbaudio.com).

#### 3.1.1. WEEE Declaration (Disposal)

Electrical and electronic equipment must be disposed of separately from normal waste at the end of its operational lifetime.

Please dispose of this product according to the respective national regulations or contractual agreements. If there are any further questions concerning the disposal of this product, please contact d&b audiotechnik.



